

OPERATOR'S MANUAL



Model C712 Soft Serve Freezer

Original Operating Instructions

062179-M

2/03/05 (Original Publication)
Updated 6/25/15

Complete this page for quick reference when service is required:

Taylor Distributor: _____

Address: _____

Phone: _____

Fax: _____

E-mail: _____

Service: _____

Parts: _____

Date of Installation: _____

Information found on the data label:

Model Number: _____

Serial Number: _____

Electrical Specs: Voltage _____ Cycle _____

Phase _____

Maximum Fuse Size: _____ A

Minimum Wire Ampacity: _____ A

© 2005 Carrier Commercial Refrigeration, Inc.
062179-M

Any unauthorized reproduction, disclosure, or distribution of copies by any person of any portion of this work may be a violation of Copyright Law of the United States of America and other countries, could result in the awarding of Statutory Damages of up to \$250,000 (17 USC 504) for infringement, and may result in further civil and criminal penalties. All rights reserved.



Taylor Company
a division of Carrier Commercial Refrigeration, Inc.
750 N. Blackhawk Blvd.
Rockton, IL 61072

Table of Contents

Section 1	To the Installer	1
	Installer Safety	1
	Site Preparation	1
	Air Cooled Units	1
	Water Connections (Water Cooled Units Only)	2
	Electrical Connections	2
	Beater Rotation	3
	Refrigerant	3
Section 2	To the Operator	4
Section 3	Safety	5
Section 4	Operator Parts Identification	7
	Model C712	7
	Model C712 Door and Beater Assembly	9
	X57029-XX Pump A. - Mix Simplified	10
	Accessories	11
	Brushes	12
Section 5	Important: To the Operator	13
	Symbol Definitions	14
	Operating Screen Descriptions	15
	Manager's Menu	16
Section 6	Operating Procedures	22
	Freezing Cylinder Assembly	22
	Mix Pump Assembly	27
	Sanitizing	29
	Priming	31
	Manual Brush Cleaning	31
	Draining Product From The Freezing Cylinder	31
	Rinsing	32
	Hopper Cleaning	32

Disassembly	33
Brush Cleaning	34
Section 7 Important: Operator Checklist	35
During Cleaning and Sanitizing	35
Troubleshooting Bacterial Count	35
Regular Maintenance Checks	35
Winter Storage	36
Section 8 Troubleshooting Guide	37
Section 9 Parts Replacement Schedule	40
Section 10 Limited Warranty on Equipment	41
Section 11 Limited Warranty on Parts	43

Note: Continuing research results in steady improvements; therefore, information in this manual is subject to change without notice.

Note: Only instructions originating from the factory or its authorized translation representative(s) are considered to be the original set of instructions.

© 2005 Carrier Commercial Refrigeration, Inc. (Original Publication)
Updated June, 2015
062179-M

Any unauthorized reproduction, disclosure, or distribution of copies by any person of any portion of this work may be a violation of Copyright Law of the United States of America and other countries, could result in the awarding of Statutory Damages of up to \$250,000 (17 USC 504) for infringement, and may result in further civil and criminal penalties.
All rights reserved.



Taylor Company
a division of Carrier Commercial Refrigeration, Inc.
750 N. Blackhawk Blvd.
Rockton, IL 61072

Section 1

To the Installer

The following information has been included in the manual as safety and regulatory guidelines. For complete installation instructions, please see the Installation Checklist.

Installer Safety



In all areas of the world, equipment should be installed in accordance with existing local codes. Please contact your local authorities if you have any questions.

Care should be taken to ensure that all basic safety practices are followed during the installation and servicing activities related to the installation and service of Taylor equipment.

- Only authorized Taylor service personnel should perform installation and repairs on the equipment.
- Authorized service personnel should consult OSHA Standard 29CFR1910.147 or the applicable code of the local area for the industry standards on lockout/tagout procedures before beginning any installation or repairs.
- Authorized service personnel must ensure that the proper PPE is available and worn when required during installation and service.
- Authorized service personnel must remove all metal jewelry, rings, and watches before working on electrical equipment.



The main power supply(s) to the freezer must be disconnected prior to performing any repairs. Failure to follow this instruction may result in personal injury or death from electrical shock or hazardous moving parts as well as poor performance or damage to the equipment.

Note: All repairs must be performed by an authorized Taylor Service Technician.



This unit has many sharp edges that can cause severe injuries.

Site Preparation

Review the area the unit is to be installed in before uncrating the unit making sure that all possible hazards the user or equipment may come into have been addressed.

Air Cooled Units

The Model C712 air cooled unit requires a minimum of 3" (76 mm) of clearance on all sides. Install the deflector provided to prevent recirculation of warm air. This will allow for adequate air flow across the condenser. Failure to allow adequate clearance can reduce the refrigeration capacity of the freezer and possibly cause permanent damage to the compressor.

For Indoor Use Only: This unit is designed to operate indoors, under normal ambient temperatures of 70°-75°F (21°-24°C). The freezer has successfully performed in high ambient temperatures of 104°(40°C) at reduced capacities.



This unit must **NOT** be installed in an area where a water jet or hose can be used. **NEVER** use a water jet or hose to rinse or clean the unit. Failure to follow this instruction may result in electrocution.



This unit must be installed on a level surface to avoid the hazard of tipping. Extreme care should be taken in moving this equipment for any reason. Two or more persons are required to safely move this unit. Failure to comply may result in personal injury or equipment damage.

Uncrate the unit and inspect it for damage. Report any damage to your Taylor Distributor.

This piece of equipment is made in the USA and has USA sizes of hardware. All metric conversions are approximate and vary in size.

Water Connections (Water Cooled Units Only)

An adequate cold water supply must be provided with a hand shut-off valve. On the underside of the base pan or on the right side, two 3/8" I.P.S. water connections for inlet and outlet are provided for easy hook-up. 1/2" inside diameter water lines should be connected to the machine. (Flexible lines are recommended, if local codes permit.) Depending on local water conditions, it may be advisable to install a water strainer to prevent foreign substances from clogging the automatic water valve. There will be only one water "in" and one water "out" connection. **DO NOT** install a hand shut-off valve on the water "out" line! Water should always flow in this order: first, through the automatic water valve; second, through the condenser; and third, through the outlet fitting to an **open trap drain**.



A back flow prevention device is required on the incoming water connection side. Please refer to the applicable National, State, and local codes for determining the proper configuration.

Electrical Connections

In the United States, this equipment is intended to be installed in accordance with the National Electrical Code (NEC), ANSI/NFPA 70-1987. The purpose of the NEC code is the practical safeguarding of persons and property from hazards arising from the use of electricity. This code contains provisions considered necessary for safety. In all other areas of the world, equipment should be installed in accordance with the existing local codes. Please contact your local authorities.



FOLLOW YOUR LOCAL ELECTRICAL CODES!

Each unit requires one power supply for each data label on the unit. Check the data label on the freezer for branch circuit overcurrent protection or fuse, circuit ampacity, and other electrical specifications. Refer to the wiring diagram provided inside the electrical box, for proper power connections.



CAUTION: THIS EQUIPMENT MUST BE PROPERLY GROUNDED! FAILURE TO DO SO CAN RESULT IN SEVERE PERSONAL INJURY FROM ELECTRICAL SHOCK!



DO NOT operate this freezer with larger fuses than specified on the unit data label. Failure to follow this instruction may result in electrocution or damage to the machine.



This unit is provided with an equipotential grounding lug that is to be properly attached to the rear of the frame by the authorized installer. The installation location is marked by the equipotential bonding symbol (5021 of IEC 60417-1) on both the removable panel and the equipments frame.



Stationary appliances which are not equipped with a power cord and a plug or another device to disconnect the appliance from the power source must have an all-pole disconnecting device with a contact gap of at least 3 mm installed in the external installation.



Appliances that are permanently connected to fixed wiring and for which leakage currents may exceed 10 mA, particularly when disconnected or not used for long periods, or during initial installation, shall have protective devices such as a GFI, to protect against the leakage of current, installed by the authorized personnel to the local codes.



Supply cords used with this unit shall be oil-resistant, sheathed flexible cable not lighter than ordinary polychloroprene or other equivalent synthetic elastomer-sheathed cord (Code designation 60245 IEC 57) installed with the proper cord anchorage to relieve conductors from strain, including twisting, at the terminals and protect the insulation of the conductors from abrasion.

If the supply cord is damaged, it must be replaced by the manufacturer, its service agent, or similarly qualified person, in order to avoid a hazard.

Beater Rotation



Beater rotation must be clockwise as viewed looking into the freezing cylinder.

Note: The following procedures should be performed by a trained service technician.

To correct the rotation on a three-phase unit, interchange any two incoming power supply lines at freezer main terminal block only.

To correct rotation on a single-phase unit, change the leads inside the beater motor. (Follow the diagram printed on the motor.)

Electrical connections are made directly to the terminal block provided in the splice box.

Refrigerant



In consideration of our environment, Taylor proudly uses only earth friendly HFC refrigerants. The HFC refrigerant used in this unit is R404A. This refrigerant is generally considered non-toxic and non-flammable, with an Ozone Depleting Potential (ODP) of zero (0). However, any gas under pressure is potentially hazardous and must be handled with caution.

NEVER fill any refrigerant cylinder completely with liquid. Filling the cylinder to approximately 80% will allow for normal expansion.



Use only R404A refrigerant that conforms to the AHRI standard 700 specification. The use of any other refrigerant may expose users and operators to unexpected safety hazards.



Refrigerant liquid sprayed onto the skin may cause serious damage to tissue. Keep eyes and skin protected. If refrigerant burns should occur, flush immediately with cold water. If burns are severe, apply ice packs and contact a physician immediately.



Taylor reminds technicians to be cautious of government laws regarding refrigerant recovery, recycling, and reclaiming systems. If you have any questions regarding these laws, please contact the factory Service Department.



WARNING: R404A refrigerant used in conjunction with polyolester oils is extremely moisture absorbent. When opening a refrigeration system, the maximum time the system is open must not exceed 15 minutes. Cap all open tubing to prevent humid air or water from being absorbed by the oil.

Section 2

To the Operator

Your freezer has been carefully engineered and manufactured to give you dependable operation.

This unit, when properly operated and cared for, will produce a consistent quality product. Like all mechanical products, it will require cleaning and maintenance. A minimum amount of care and attention is necessary if the operating procedures outlined in this manual are followed closely.

This Operator's Manual should be read before operating or performing any maintenance on your equipment.

Your Taylor freezer will NOT eventually compensate for and correct any errors during the set-up or filling operations. Thus, the initial assembly and priming procedures are of extreme importance. It is strongly recommended that personnel responsible for the equipment's operation, both assembly and disassembly, go through these procedures together in order to be properly trained and to make sure that no confusion exists.

In the event you should require technical assistance, please contact your local authorized Taylor Distributor.

Note: Your Taylor warranty is valid only if the parts are authorized Taylor parts, purchased from the local authorized Taylor Distributor, and only if all required service work is provided by an authorized Taylor service technician. Taylor reserves the right to deny warranty claims on units or parts if non-Taylor approved parts or incorrect refrigerant were installed in the unit, system modifications were performed beyond factory recommendations, or it is determined that the failure was caused by abuse, misuse, neglect, or failure to follow all operating instructions. For full details of your Taylor Warranty, please see the Limited Warranty section in this manual.

Note: Constant research results in steady improvements; therefore, information in this manual is subject to change without notice.



If the crossed out wheeled bin symbol is affixed to this product, it signifies that this product is compliant with the EU Directive as well as other

similar legislation in effect after August 13, 2005. Therefore, it must be collected separately after its use is completed, and cannot be disposed as unsorted municipal waste.

The user is responsible for returning the product to the appropriate collection facility, as specified by your local code.

For additional information regarding applicable local laws, please contact the municipal facility and/or local distributor.

Compressor Warranty Disclaimer

The refrigeration compressor(s) on this unit are warranted for the term stated in the Limited Warranty section in this manual. However, due to the Montreal Protocol and the U.S. Clean Air Act Amendments of 1990, many new refrigerants are being tested and developed, thus seeking their way into the service industry. Some of these new refrigerants are being advertised as drop-in replacements for numerous applications. It should be noted that in the event of ordinary service to this unit's refrigeration system, **only the refrigerant specified on the affixed data label should be used**. The unauthorized use of alternate refrigerants will void your Taylor compressor warranty. It is the unit owner's responsibility to make this fact known to any technician he employs.

It should also be noted that Taylor does not warrant the refrigerant used in its equipment. For example, if the refrigerant is lost during the course of ordinary service to this machine, Taylor has no obligation to either supply or provide its replacement either at billable or unbillable terms. Taylor does have the obligation to recommend a suitable replacement if the original refrigerant is banned, obsoleted, or no longer available during the five year warranty of the compressor.

Taylor will continue to monitor the industry and test new alternates as they are being developed. Should a new alternate prove, through our testing, that it would be accepted as a drop-in replacement, then the above disclaimer would become null and void. To find out the current status of an alternate refrigerant as it relates to your compressor warranty, call the local Taylor Distributor or the Taylor Factory. Be prepared to provide the Model/Serial Number of the unit in question.

We at Taylor are concerned about the safety of the operator when he or she comes in contact with the freezer and its parts. Taylor has gone to extreme efforts to design and manufacture built-in safety features to protect both you and the service technician. As an example, warning labels have been attached to the freezer to further point out safety precautions to the operator.

To Operate Safely:



IMPORTANT - Failure to adhere to the following safety precautions may result in severe personal injury or death. Failure to comply with these warnings may damage the machine and its components. Component damage will result in part replacement expense and service repair expense.



DO NOT operate the freezer without reading this Operator Manual. Failure to follow this instruction may result in equipment damage, poor freezer performance, health hazards, or personal injury.



This appliance is to be used only by trained personnel. It is not intended for use by children or people with reduced physical, sensory, or mental capabilities, or lack of experience and knowledge, unless given supervision or instruction concerning the use of the appliance by a person responsible for their safety. Children should be supervised to ensure that they do not play with the appliance.



This unit is provided with an equipotential grounding lug that is to be properly attached to the rear of the frame by the authorized installer. The installation location is marked by the equipotential bonding symbol (5021 of IEC 60417-1) on both the removable panel and the equipments frame.



- **DO NOT** operate the freezer unless it is properly grounded.
- **DO NOT** operate the freezer with larger fuses than specified on the freezer data label.
- All repairs must be performed by an authorized Taylor service technician. The main power supplies to the machine must be disconnected prior to performing any repairs.
- For Cord Connected Units: Only Taylor authorized service technicians or licensed electricians may install a plug or replacement cord on this unit.
- Stationary appliances which are not equipped with a power cord and a plug or another device to disconnect the appliance from the power source must have an all-pole disconnecting device with a contact gap of at least 3 mm installed in the external installation.
- Appliances that are permanently connected to fixed wiring and for which leakage currents may exceed 10 mA, particularly when disconnected or not used for long periods, or during initial installation, shall have protective devices such as a GFI, to protect against the leakage of current, installed by the authorized personnel to the local codes.
- Supply cords used with this unit shall be oil-resistant, sheathed flexible cable not lighter than ordinary polychloroprene or other equivalent synthetic elastomer-sheathed cord (Code designation 60245 IEC 57) installed with the proper cord anchorage to relieve conductors from strain, including twisting, at the terminals and protect the insulation of the conductors from abrasion.

If the supply cord is damaged, it must be replaced by the manufacturer, its service agent, or similarly qualified person, in order to avoid a hazard.

Failure to follow these instructions may result in electrocution. Contact your local authorized Taylor Distributor for service.



DO NOT use a water jet to clean or rinse the freezer. Failure to follow these instructions may result in serious electrical shock.



- **DO NOT** allow untrained personnel to operate this machine.
- **DO NOT** operate the freezer unless all service panels and access doors are restrained with screws.
- **DO NOT** remove any internal operating parts (examples: freezer door, beater, scraper blades, etc.) unless all control switches are in the OFF position.

Failure to follow these instructions may result in severe personal injury to fingers or hands from hazardous moving parts.



This unit has many sharp edges that can cause severe injuries.

- **DO NOT** put objects or fingers in the door spout. This may contaminate the product and cause severe personal injury from blade contact.
- **USE EXTREME CAUTION** when removing the beater assembly. The scraper blades are very sharp.
- **CAUTION-SHARP EDGES:** Two people are required to handle the cup/cone dispenser. Protective gloves must be worn and the mounting holes must NOT be used to lift or hold the dispenser. Failure to follow this instruction can result in personal injury to fingers or equipment damage.



Access to the service area of the unit is restricted to persons having knowledge and practical experience with the appliance, in particular as far as safety and hygiene are concerned.



This freezer must be placed on a level surface. Failure to comply may result in personal injury or equipment damage.



Cleaning and sanitizing schedules are governed by your state or local regulatory agencies and must be followed accordingly. Please refer to the cleaning section of this manual for the proper procedure to clean this unit.



This machine is designed to maintain product temperature under 41°F (5°C). Any product being added to this machine must be below 41°F (5°C). Failure to follow this instruction may result in health hazards and poor freezer performance.

DO NOT obstruct air intake and discharge openings:

A minimum of 3" (76 mm) air space is required on all sides. Install the deflector provided to prevent recirculation of warm air. Failure to follow this instruction may cause poor freezer performance and damage to the machine.

For Indoor Use Only: This unit is designed to operate indoors, under normal ambient temperatures of 70° - 75°F (21° - 24°C). The freezer has successfully performed in high ambient temperatures of 104° (40°C) at reduced capacities.

DO NOT run the machine without product. Failure to follow this instruction can result in damage to the machine.

NOISE LEVEL: Airborne noise emission does not exceed 78 dB(A) when measured at a distance of 1.0 meter from the surface of the machine and at a height of 1.6 meters from the floor.

Section 4

Operator Parts Identification

Model C712

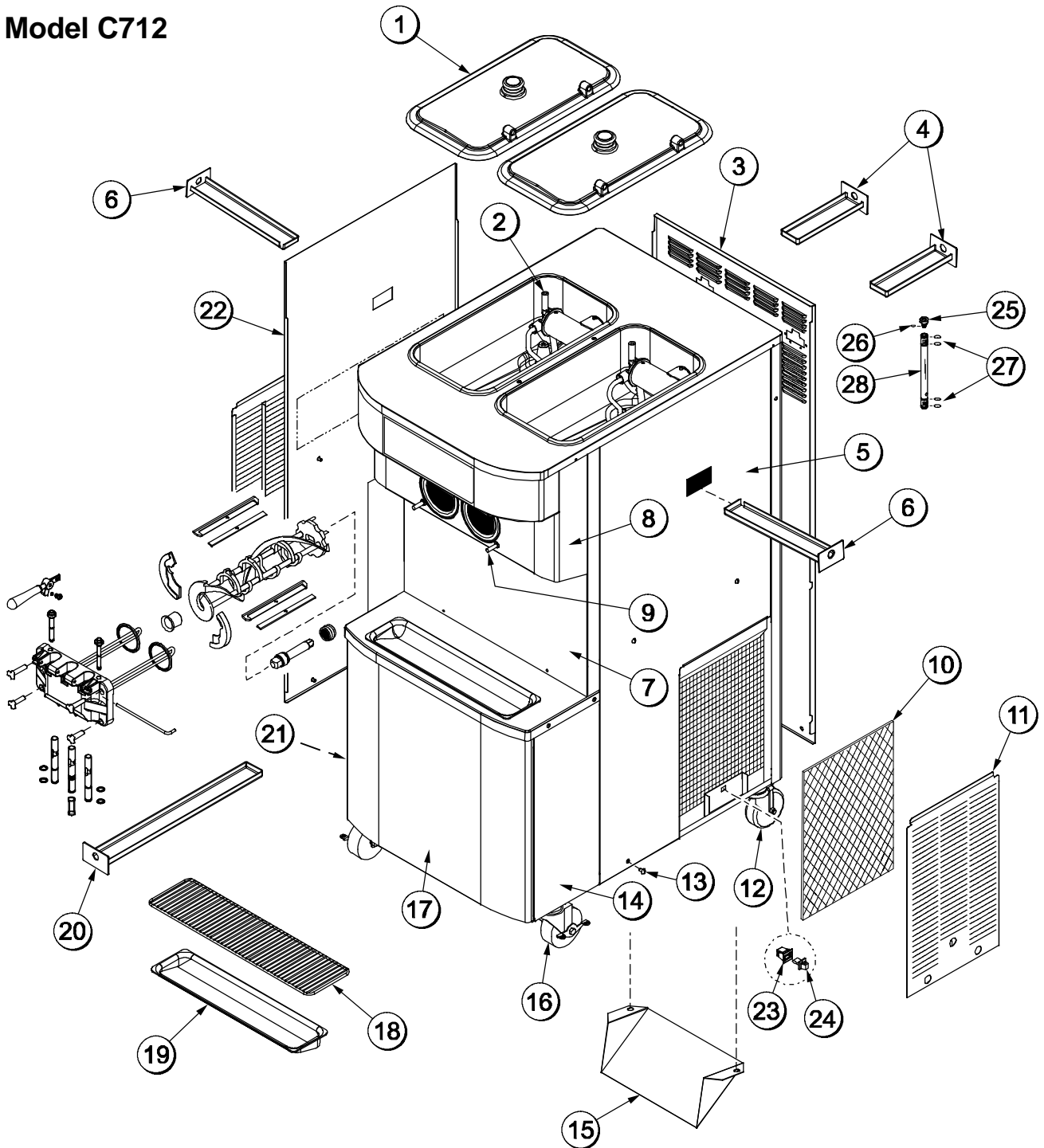

Figure 1

C712 Exploded View Parts Identification

ITEM	DESCRIPTION	PART NO.
1	KIT A.-COVER-HOPPER*DUAL	X67061-SP
2	PUMP A.-MIX SIMPLIFIED	X57029-14 *SEE PG 10
3	PANEL-REAR	064258-SER
4	PAN-DRIP 7.875	059737
5	PANEL-SIDE*RIGHT	059907
6	PAN-DRIP 12.5	059736
7	PANEL A.-FRONT-MIDDLE	X63879
8	PANEL A.-FRONT-UPPER	X59836
9	STUD-NOSE CONE	055987
10	FILTER-AIR-POLY-FLO	052779-11
11	PANEL A.-FILTER-LOUVERED	X59928
12	CASTER-4" SWV 3/4-10 STM	044106
13	SCREW-1/4-20 X 3/8 RHM	011694
14	PANEL-CORNER-FRONT-R	063087
15	DEFLECTOR-BLOWER EXH	047912

ITEM	DESCRIPTION	PART NO.
16	CASTER-4" SWV 3/4-10 STEM W/BRAKE	046437
17	PANEL A.-FRONT LOWER	X59854-SER
18	SHIELD-SPLASH-WIRE-19-3/4 L	033813
19	TRAY-DRIP-19-5/8 L X 4-7/8	033812
20	PAN-DRIP 19-1/2 LONG	035034
21	PANEL-CORNER-FRNT-L	063088
22	PANEL-SIDE-LEFT	059906
23	FASTENER-DOOR LATCH	030787
24	FASTENER-DOOR STRIKE	030788
25	ORIFICE	022465-100
26	O-RING-3/8 OD X .070W (100 TO BAG)	016137
27	O-RING-.643 OD X .077W (50 TO BAG)	018572
28	TUBE A.-FEED-SS-5/32 HOLE	X29429-2

Model C712 Door and Beater Assembly

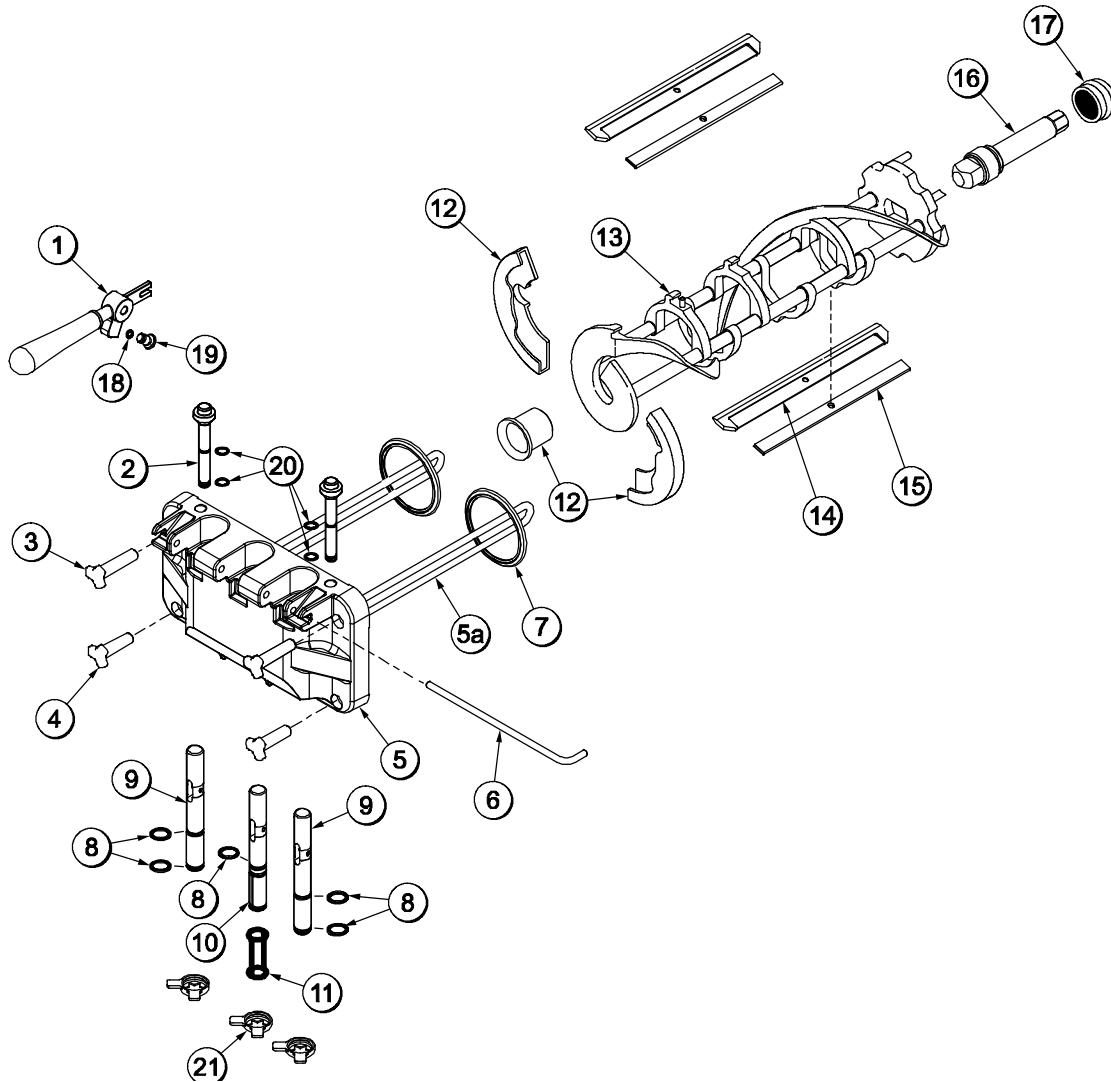

Figure 2

ITEM	DESCRIPTION	PART NO.
1	HANDLE A.-DRAW-WELDED	X56421-1
2	PLUG-PRIME TWIN	059936
3	NUT-STUD-BLACK 3.250 LONG	058765
4	NUT-STUD-BLACK 2.563 LONG	058764
5	DOOR A.-3SPT*LG BAF	X59921-SER
5a	BAFFLE A.-LONG 4 IN W/RAD	X50882
6	PIN-HANDLE-TWIN	059894
7	GASKET-DOOR HT 4"-DOUBLE	048926
8	O-RING-7/8 OD X .103 W	014402
9	VALVE A.-DRAW	X59843
10	VALVE A.-DRAW CENTER	X62218
11	SEAL-DRAW VALVE	034698

ITEM	DESCRIPTION	PART NO.
12	KIT A.-BEATER-FRONT SHOES-BEARING	X50350
13	BEATER A.-3.4QT-1 PIN	X46231
14	BLADE-SCRAPER-PLASTIC	046235
15	CLIP-SCRAPER BLADE 7.00	046236
16	SHAFT-BEATER	032564
17	SEAL-DRIVE SHAFT	032560
18	O-RING-1/4 OD X .070W 50	015872
19	SCREW-ADJUSTMENT-5/16-24	056332
20	O-RING-.500 OD X .070W	024278
21	CAP-DESIGN 1.010"ID-6 POINT	014218

X57029-XX Pump A. - Mix Simplified

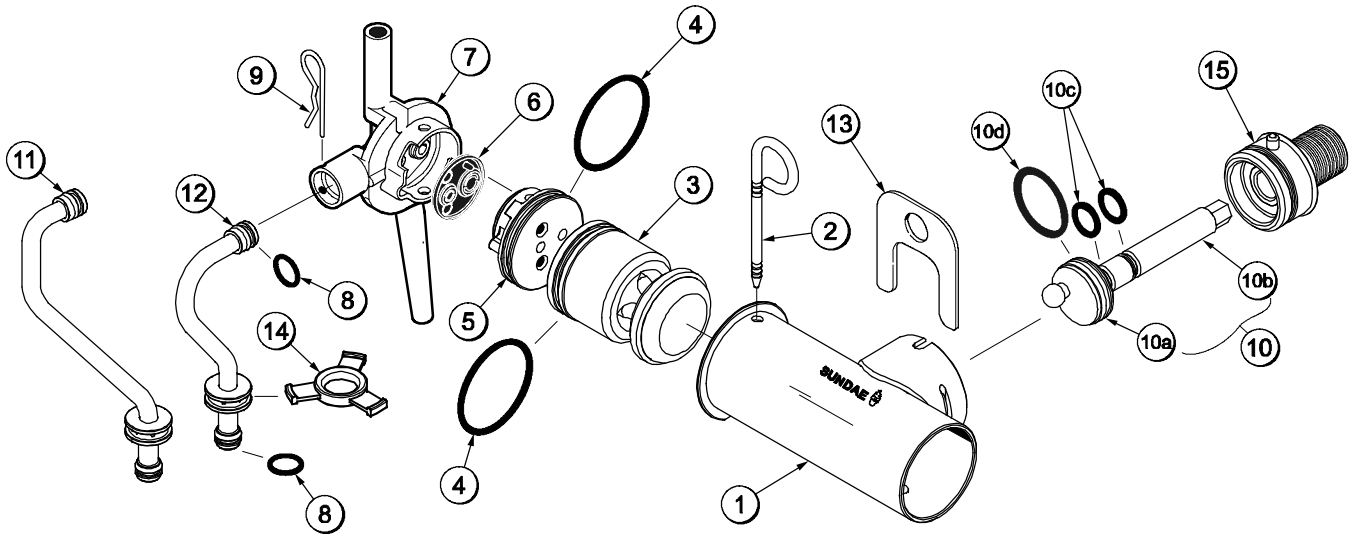

Figure 3

ITEM	DESCRIPTION	PART NO.
1 - 7	PUMP ASSEMBLY - MIX SIMPLIFIED SOFT SERVE	X57029-14*
1	CYLINDER-PUMP-HOPPER-SOFT SERVE	057943
2	PIN-RETAINING	X55450
3	PISTON	053526
4	O-RING 2-1/8" OD - RED	020051
5	CAP-VALVE	056874-14*
6	GASKET - SIMPLIFIED PUMP VALVE	053527
7	ADAPTOR - MIX INLET	054825
8	O-RING - 11/16 OD - RED	016132

ITEM	DESCRIPTION	PART NO.
9	PIN - COTTER	044731
10	SHAFT A.-DRIVE-MIX PUMP	X41947
10a	CRANK-DRIVE	039235
10b	SHAFT-DRIVE	041948
10c	O-RING - DRIVE SHAFT	048632
10d	O-RING 1-3/4	008904
11	TUBE A.-FEED-LEFT	X59808
12	TUBE A.-FEED-RIGHT	X59809
13	CLIP-RETAINER-MIX PUMP	044641
14	RING-CHECK-FEED TUBE	056524
15	SLEEVE A.-MIX PUMP *HT	X44761

***NOTE:** THE STANDARD PUMP IS X57029-14. OVERRUN CAN BE CHANGED HIGHER OR LOWER BY SUBSTITUTING THE VALVE BODY CAP. THE HIGHER THE (-) THE HIGHER THE OVERRUN. YOUR UNIT INCLUDES 2 OPTIONAL CAPS, 056874-12 AND 056874-16.

Accessories

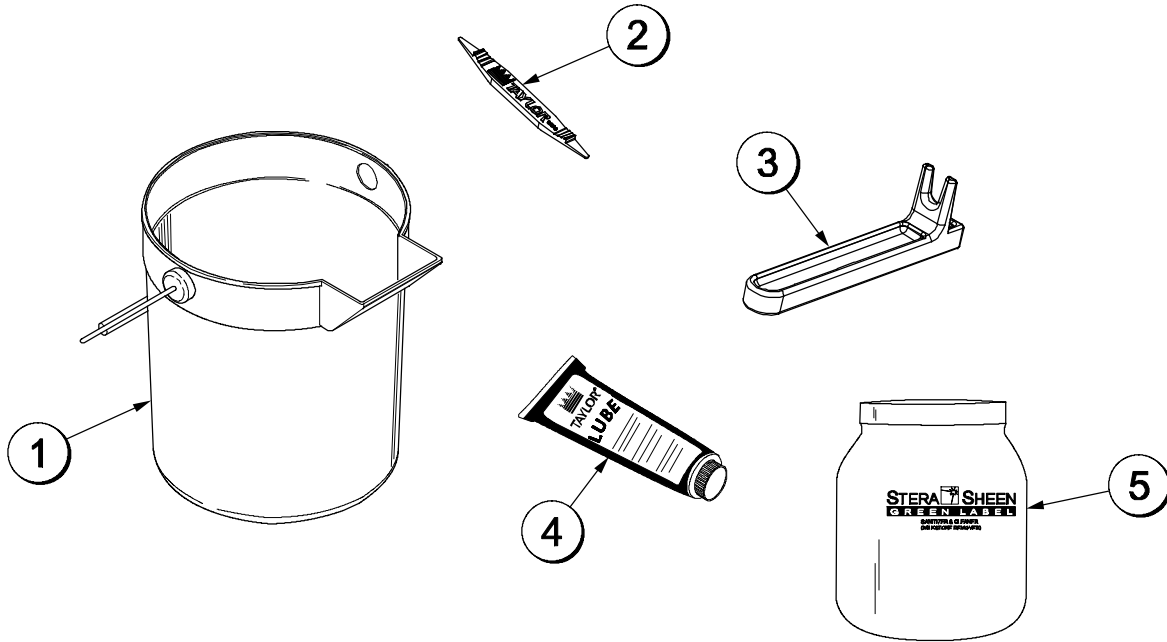

Figure 4

ITEM	DESCRIPTION	PART NO.
1	PAIL-10 QT.	013163
2	TOOL-O-RING REMOVAL	048260-WHT
3	TOOL-MIX PUMP SHAFT REMOVAL	057167

ITEM	DESCRIPTION	PART NO.
4	LUBRICANT-TAYLOR 4 OZ.	047518
*5	SANITIZER-STERA SHEEN	SEE NOTE
**	KIT A.-TUNE-UP C712	X49463-81

***Note:** A sample container of sanitizer is sent with the unit. For reorders, order Stera Sheen part no. 055492 (100 packs) or Kay-5 part no. 041082 (125 packs).

**Not Shown

Brushes

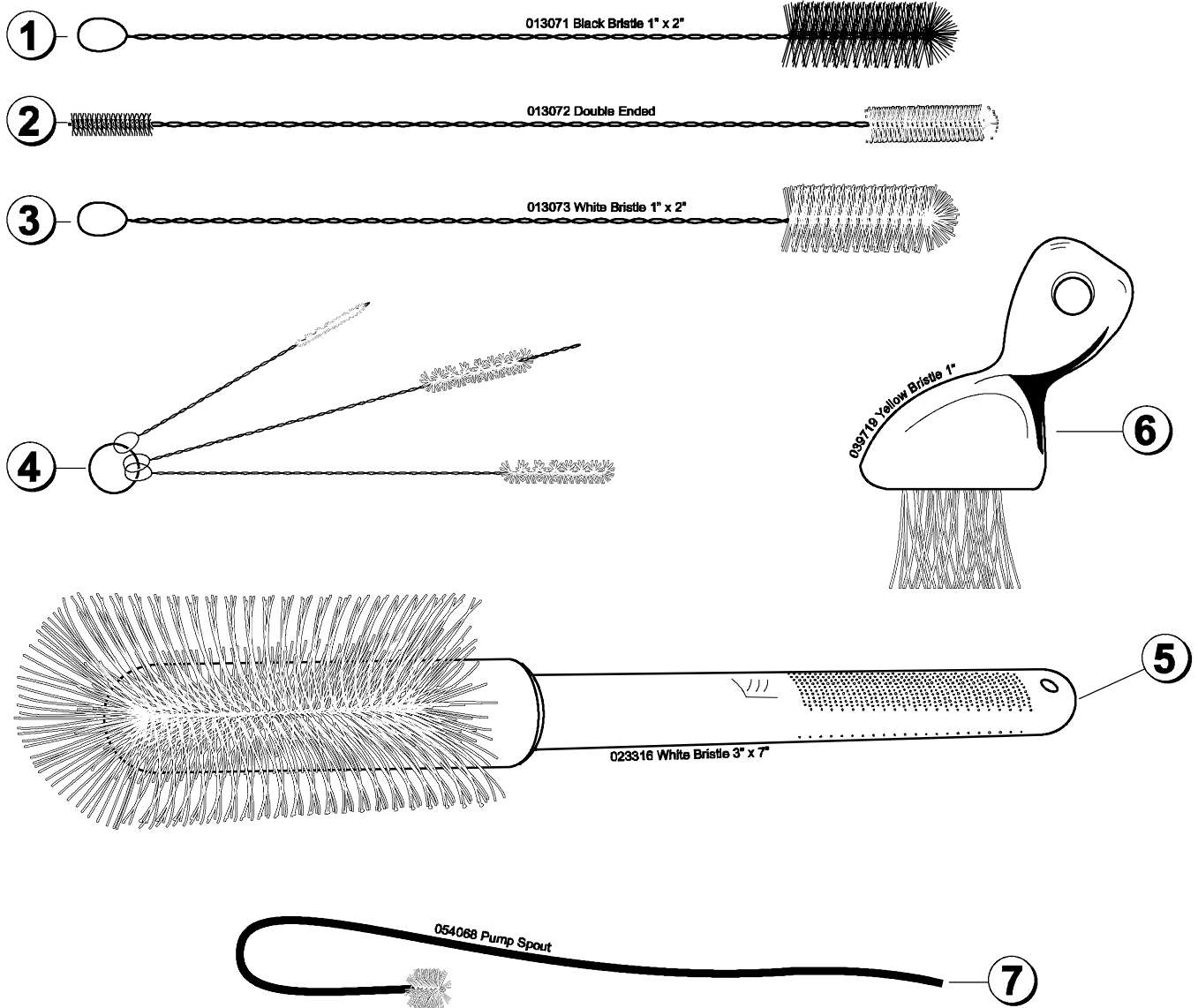

Figure 5

ITEM	DESCRIPTION	PART NO.
1	BLACK BRISTLE BRUSH	013071
2	DOUBLE END BRUSH	013072
3	WHITE BRISTLE BRUSH (1" x 2")	013073
4	BRUSH SET (3)	050103

ITEM	DESCRIPTION	PART NO.
5	WHITE BRISTLE BRUSH (3" x 7")	023316
6	BRUSH-END-DOOR-SPOUT	039719
7	BRUSH-PUMP SPOUT	054068

Section 5

Important: To the Operator

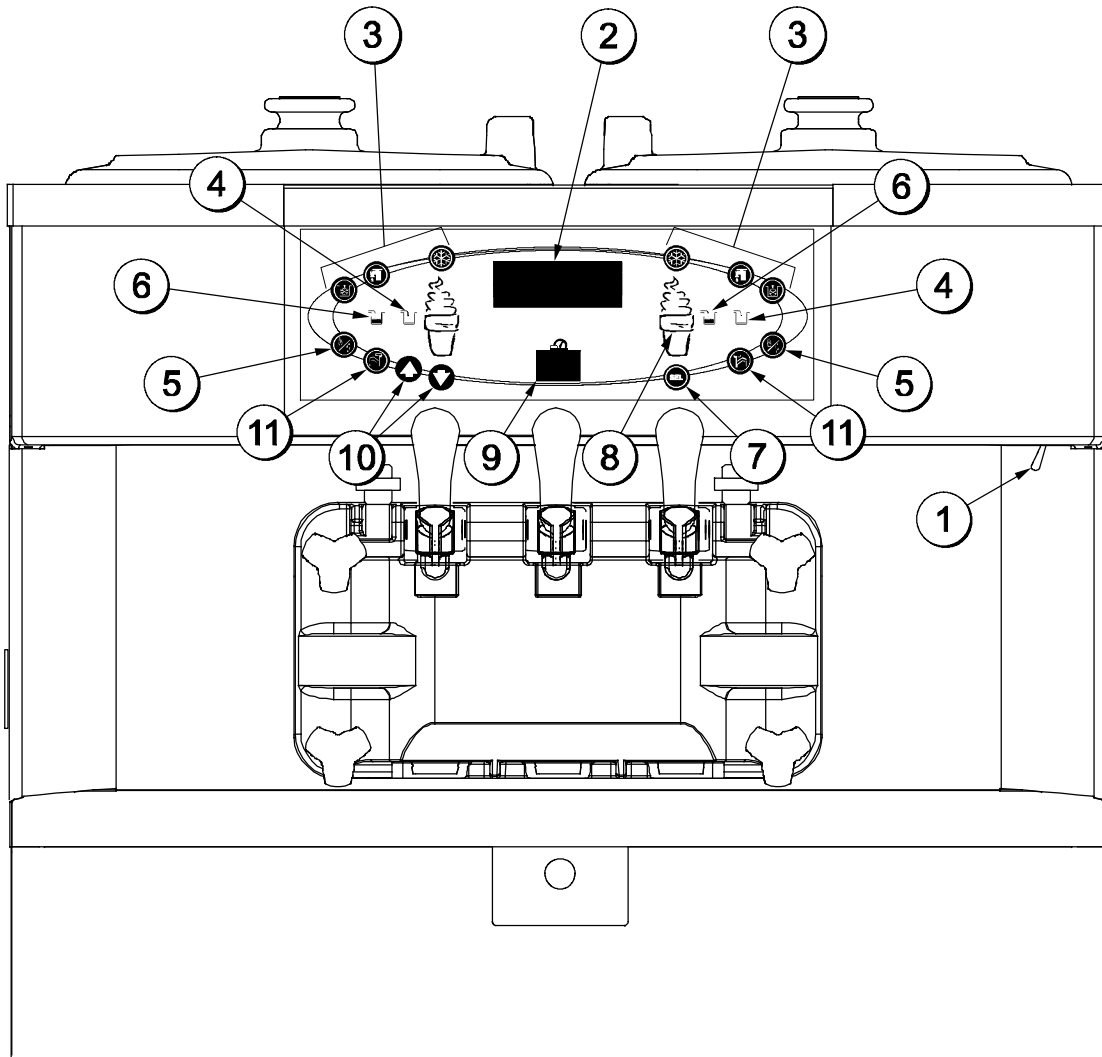

Figure 6

ITEM	DESCRIPTION
1	POWER SWITCH
2	FLUORESCENT DISPLAY
3	KEYPADS
4	MIX OUT INDICATOR
5	STANDBY KEY
6	MIX LOW INDICATOR

ITEM	DESCRIPTION
7	SELECT KEY
8	SERVICE MENU KEY
9	BRUSH CLEAN COUNTER
10	ARROW KEYS
11	SYRUP TOPPING HEATER KEY

Symbol Definitions

To better communicate in the International arena, symbols have replaced words on many of our operator switches, function, and fault indicators. Your Taylor equipment is designed with these International symbols.

The following chart identifies the symbol definitions.

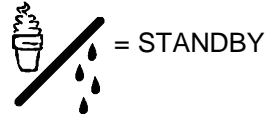
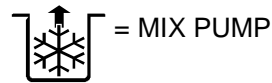
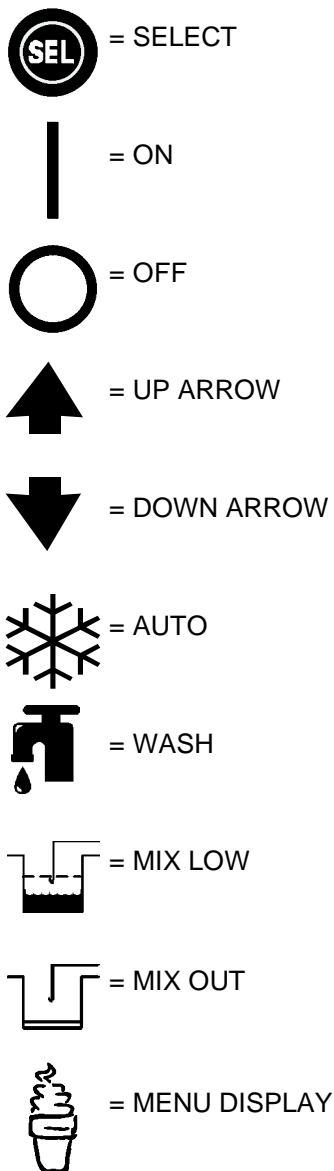

Power Switch



When placed in the ON position, the power switch allows control panel operation.

Fluorescent Display

The fluorescent display is located on the front control panel. During normal operation the display is blank. The display is used to show menu options and notifies the operator if a fault is detected. On International models, the display will indicate the temperature of the mix in the hopper.

Indicator Lights

MIX LOW - When the MIX LOW symbol  is illuminated, the mix hopper has a low supply of mix and should be refilled as soon as possible.

MIX OUT - When the MIX OUT  symbol is illuminated, the mix hopper has been almost completely exhausted and has an insufficient supply of mix to operate the freezer. At this time, the AUTO mode is locked out and the freezer will be placed in the STANDBY mode. To initiate the refrigeration system, add mix to the mix hopper and touch the AUTO symbol . The freezer will automatically begin operation.

Standby Symbol

During long "No Sale" periods, the unit can be placed into the Standby mode. This maintains product temperatures below 40°F (4.4°C) in both the hopper and the freezing cylinder, and helps prevent overheating and product breakdown.

When STANDBY is selected, the STANDBY symbol  illuminates, indicating the Standby feature has been activated.



To resume normal operation, press the AUTO symbol . When the unit cycles off, the product in the freezing cylinder will be at serving viscosity.

Reset Mechanism

The reset buttons are located in the back panel of the machine. It protects the beater motor from an overload condition. Should an overload occur, the reset mechanism will trip. To properly reset the freezer place the power switch in the OFF position. Press the reset button firmly. Turn the power switch to the ON position. Touch the WASH symbol  and observe the freezer's performance.



WARNING: Do not use metal objects to press the reset button. Failure to comply may result in severe personal injury or death.

If the beater motor is turning properly, touch the WASH symbol  to cancel the cycle. Touch the AUTO symbol  to resume normal operation. If the freezer shuts down again, contact your authorized service technician.

Air/Mix Pump Reset Mechanism

This reset button protects the pump from an overload condition. Should an overload occur, the reset mechanism will trip. To reset the pump, press the reset button firmly.



WARNING: Do not use metal objects to press the reset button. Failure to comply may result in severe personal injury or death.

Adjustable Draw Handle

This unit features an adjustable draw handle to provide the best portion control, giving a better, consistent quality to your product and controlling costs. The draw handle should be adjusted to provide a flow rate of 5 to 7-1/2 oz. (142 to 213 g.) of product by weight per 10 seconds. To INCREASE the flow rate, tighten the screw. To DECREASE the flow rate, loosen the screw. (See Figure 7.)

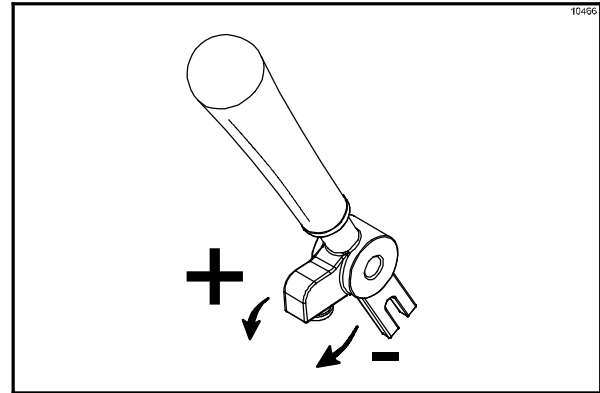

Figure 7

Operating Screen Descriptions

The fluorescent display located in the center of the control panel is normally blank during the daily operation of the machine. The display is activated when the SEL symbol or the Manager's Menu is selected. The display screen will also alert the operator of specific faults detected by the control.

Power Up

When the machine is powered the control system will initialize to perform a system check. The screen will display "INITIALIZING". There will be four types of data the system will check: LANGUAGE, SYSTEM DATA, CONFIG DATA, and LOCKOUT DATA.

During the INITIALIZING... LANGUAGE screen, the alarm will be on. If the system detects corrupt data during INITIALIZING, the following display will alert the operator that the control settings may have been changed.

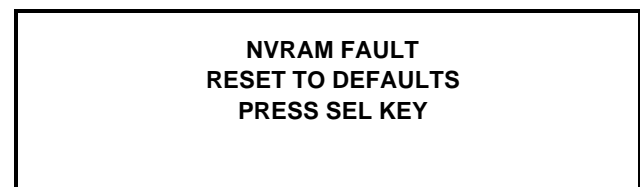

See "NVRAM FAULT" for instructions if the above message appears on the screen.

Once the system has initialized, the SAFETY TIMEOUT screen will display and the alarm will be on.

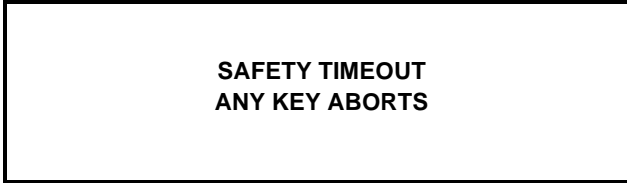

The SAFETY TIMEOUT screen will be displayed with the alarm on, for 60 seconds or until any control symbol is selected.

After the safety timeout has been completed and the power switch is OFF, the following screen is displayed.

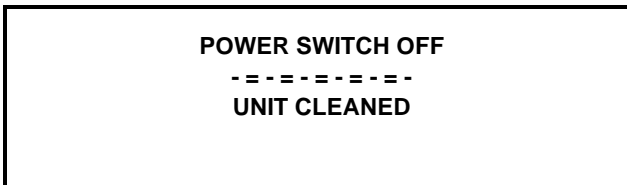

Power Switch ON

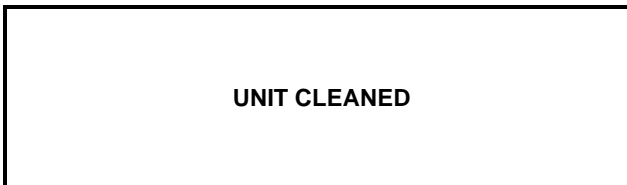

When the power switch is placed in the ON position, the control panel touch keys become operative. The fluorescent display will be either blank or indicate that the unit has been cleaned.



Brush Clean Counter

The Brush Clean Counter (item 9 on page 13) will display the number of hours since the freezer was last brush cleaned. After hour 99, it will change to a letter and a number (example: A0, A1. . B0, B1, etc.)

Manager's Menu

The Manager's Menu is used to enter the operator function displays. To access the Menu, touch the center of the CONE symbol  on the control panel. The arrow symbols, the SEL symbol and the CONE symbol  will be lit when the ACCESS CODE screen is displayed. (See Figure 8.)

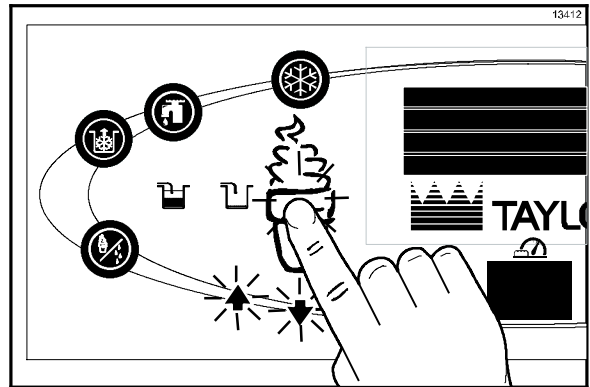

Figure 8

In the Menu program, the arrow symbols and the SEL symbol will function as menu keys.

UP ARROW - increases the value above the cursor and is used to scroll upward in text displays.

DOWN ARROW - decreases the value above the cursor and is used to scroll downward in text displays.

SEL - advances the cursor position to the right and is used to select menu options.

Note: The machine will continue operation in the mode it was in when the Menu was selected. However, the control keys will not be illuminated and are non-functional when the Manager's Menu is displayed.

Entering Access Code

With the ACCESS CODE screen on the display use the SEL symbol to set the first code number in the cursor position. When the correct number is selected, touch the SEL symbol to move the cursor to the next number position.

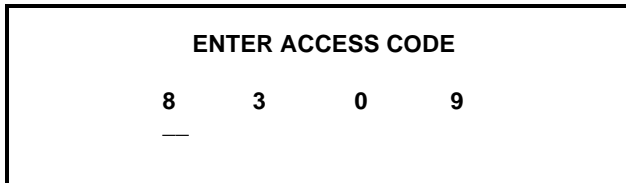

Continue to enter the proper access code numbers (8309) until all four numbers are displayed, then touch the SEL symbol. The Manager's menu list will display on the screen provided the correct access code is entered.

If an incorrect number is entered for the access code, the display will exit the Menu program when the SEL symbol is selected. (See Figure 9.)

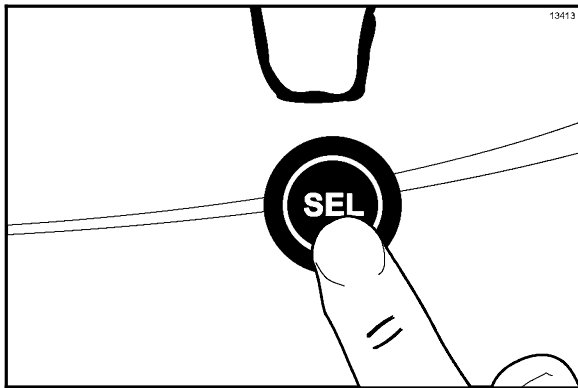



Figure 9

Menu Options

Touch the ARROW symbols to move up or down through the Menu. Select a Menu option by touching the SEL symbol. Exit the Menu program by selecting EXIT FROM MENU or touch the CONE symbol .

The following menu options are listed in the Manager's Menu.

- EXIT FROM MENU
- SERVINGS COUNTER
- SET CLOCK
- AUTO START TIME
- STANDBY MODE
- MIX LEVEL AUDIBLE
- FAULT DESCRIPTION
- FAULT HISTORY
- LOCKOUT HISTORY
- SYSTEM INFORMATION
- CURRENT CONDITIONS
- NET SERVICE PIN

Exit From Menu

Selecting "EXIT FROM MENU" will exit the Manager's Menu and return the control panel keys to normal operation.

Servings Counter

The SERVINGS COUNTER screen is used to check or reset the number of servings dispensed from the unit. The SERVING COUNTER will automatically reset to zero when the unit is brush cleaned.

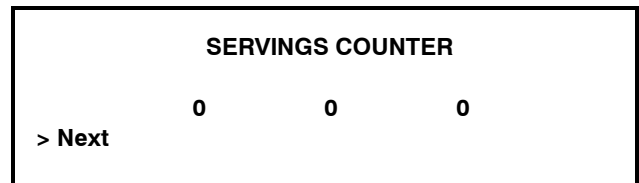

Reset the SERVINGS COUNTER by pressing the SEL key which advances to the next screen. Touch the UP arrow key to move the arrow (>) to "YES" and then touch the SEL key. The servings counter will reset to zero and exit back to the Manager's Menu.

Reset Counters
ARE YOU SURE?
 > Yes
 No

Set Clock

The SET CLOCK option allows the manager or service technician to adjust the real time clock if the unit is in the brush cleaned state. The following message will display if the Set Clock option is selected when the unit is NOT in a brush clean state.

SET CLOCK
 12:01 10/24/2014
NO CHANGES ALLOWED
 Press Any Key

If the unit is in the brush cleaned state, pressing the SEL key would display the following screen.

SET CLOCK
 12:01 10/24/2014
 Change
 > Exit

To make any changes, press the UP arrow to move to "Change" and press the SEL key. Pressing the SEL key will scroll the cursor to the right one digit for each key press. Pressing the UP or DOWN keys increases or decreases the selected digits.

SET CLOCK
 12:01 10/24/2014
 > Exit

After all changes have been made and the year has been set, pressing the SEL key will display the first DAYLIGHT SAVING TIME (DST) screen.

DAYLIGHT SAVING TIME
ENABLED
 > Enable
 Disable

Pressing the UP or DOWN arrow keys will move the arrow to "Enable" or "Disable". Pressing the SEL key next to "Disable" will disable Daylight Saving Time and return to the Manager Menu. Pressing the SEL key next to "Enable" selects that option and displays the Month and Sunday screen.

MAR Second Sunday
NOV First Sunday
 Change
 > Exit

If the correct Sunday for the time change is not displayed, then "Change" should be selected. Pressing the SEL key with the arrow next to "Change" displays the DST Start Month screen. Press the UP or DOWN key to move the arrow to the appropriate month for the start of DST.

DST START MONTH
 > MAR
 APR
 MAY

Pressing the SEL key with the arrow next to the appropriate month selects the Start Month and then displays the DST Start Week screen. Pressing the UP or DOWN key will move the arrow to the appropriate week for the start of DST.

DST START WEEK
 > Second Sunday
 Third Sunday
 Fourth Sunday

Pressing the SEL key next to the appropriate week will display the DST End Month screen. Press the UP or DOWN key to move the arrow to the appropriate month for the end of DST.



Pressing the SEL key next to the appropriate month will display the DST End Week screen. Press the UP or DOWN key to move the arrow to the appropriate week for the end of DST.

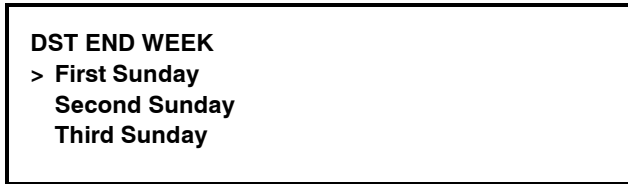

Pressing the SEL key with the arrow next to the appropriate week will select that setting and return to the Menu screen.

Auto Start Time

The AUTO START TIME option allows the Manager to set the time of day at which the unit automatically enters the AUTO mode from the STANDBY mode. The unit must be in the STANDBY mode without a freezer lock condition in order to AUTO START at the programmable time. The AUTO START TIME can also be Disabled and require starting the AUTO mode manually.

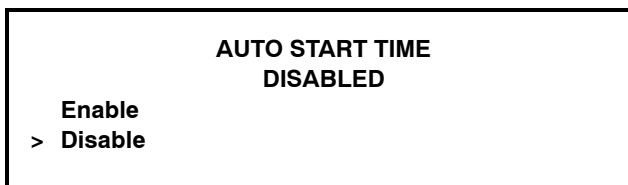

Enable the AUTO START TIME by pressing the UP arrow key to move the arrow up to "Enable". Touch the SEL key to advance to the next screen.

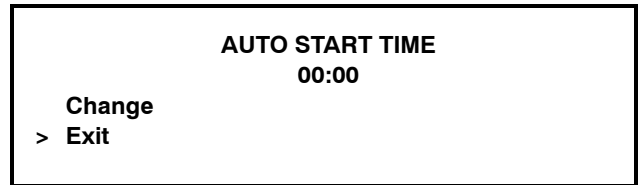

Program the AUTO START TIME by pressing the UP arrow key to move the arrow to "Change". Touch the SEL key to advance to the next screen.

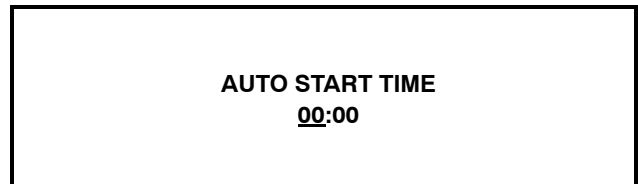

Use the arrow keys to program the AUTO START TIME by increasing or decreasing the hour setting above the cursor. Touch the SEL key to advance the cursor and program the minutes setting. Touch the SEL key to return to the previous screen with the new time setting displayed. Touch the SEL key to exit the screen and return to the Manager's Menu.

Standby Mode

The STANDBY option is used to manually place the unit in the Standby mode during long, no draw periods. Press the UP key to place the arrow next to the appropriate side. Press the SEL key to place that side of the unit into Standby and return to the main menu screen.

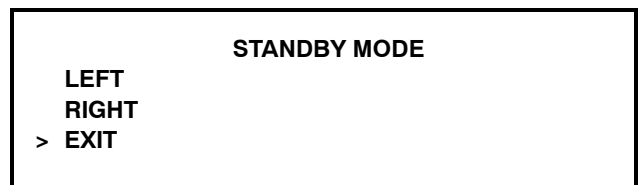

Mix Level Audible

The MIX LEVEL AUDIBLE option, when enabled, will alert the operator with an audible tone when there is Mix Low or Mix Out condition. The following screen is displayed upon selecting this option.

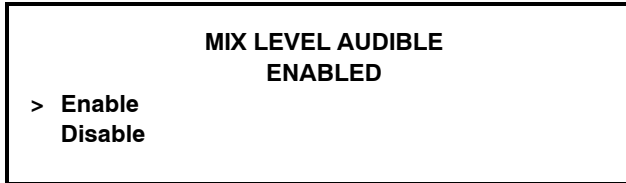

Disable the audible tone feature by pressing the DOWN arrow key to move the arrow to "Disable". Touch the SEL key to save the new setting and return to the Manager's Menu. The control panel icons for Mix Low and Mix Out will illuminate as the mix level drops in the hopper, but the audible tone will be disabled.

Fault Description

The fluorescent display is located on the front control panel. During normal operation, the display is blank. The display is used to show menu options and notifies the operator if a fault is detected. On International models, the display will indicate the temperature of the mix in the hopper. If a fault does occur, it will appear on the display.

NO FAULT FOUND - There was no fault found in the freezer. Nothing will appear on the screen after this variable message appears.

BEATER OVERLOAD - Place the power switch in the OFF position. Press the beater reset button firmly. Place the power switch in the ON position and restart in AUTO.

HPCO COMPRESSOR - Place the power switch in the OFF position. Wait 5 minutes for the unit to cool. Place the power switch in the ON position and restart in AUTO.

PRODUCT DOOR OFF - The door must be installed on the unit.

***HOPPER THERMISTOR FAIL** - Place the power switch in the OFF position. Replace the hopper thermistor probe.

***BARREL THERMISTOR FAIL** - Place the power switch in the OFF position. Replace the barrel thermistor probe.

***Note:** Three codes have been set up to assist in diagnosing bad thermistor probes. If a probe has shorted (resistance less than 1 ohm), "SHRT" will be displayed on the screen for its respective unit location. If the probe is open (resistance above 1 megohm), "OPEN" will be displayed. If the actual probe environment exceeds 200 °F (93°C), the respective screen display location will read "OVER" indicating the temperature is "out of range".

Fault History

The FAULT HISTORY will display up to 100 faults that have occurred. Page numbers are displayed in the upper right hand corner. Page one contains the most recent fault. Pressing the UP key cycles through the Fault History pages from most recent to oldest. Pressing the DOWN key cycles from the oldest to the most recent. The date and time of the event are displayed on the second line. The third line displays the reason for the fault.

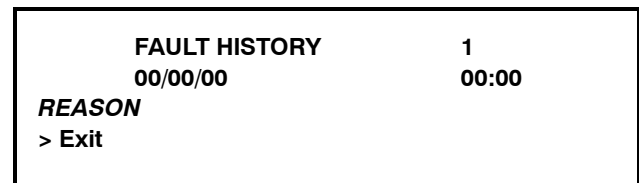

Faults Occurring While in AUTO or STANDBY Mode

(L/R) HPR>41F (5C) AFTER 4 HR - The mix temperature in the hopper was above 41°F (5°C) more than four hours.

(L/R) BRL>41F (5C) AFTER 4 HR - The mix temperature in the freezing cylinder was above 41°F (5°C) more than four hours.

(L/R) HPR>41F (5C) AFTER PF - The mix temperature in the hopper was above 41°F (5°C) more than four hours following a power failure.

(L/R) HPR>45F (7C) AFTER 1 HR - The mix temperature in the left or right hopper was above 45°F (7°C) more than one hour.

(L/R) BRL>45F (7C) AFTER 1 HR - The mix temperature in the left or right barrel was above 45°F (7°C) more than one hour.

(L/R) BRL>41F (5C) AFTER PF - The mix temperature in the freezing cylinder was above 41°F (5°C) more than four hours following a power failure.

(L/R) HPR>59F (15C) - The mix temperature in the hopper exceeded 59°F (15°C).

(L/R) BRL>59F (15C) - The mix temperature in the hopper exceeded 59°F (15°C).

(L/R) COMP ON TOO LONG - The compressor run time exceeded the 11 minute timer.

Note: Refer to your local health codes regarding temperature recommendations for procedures to follow if these fault screens appear.

Lockout History

The LOCKOUT HISTORY screen displays a history of the last 100 soft locks, hard locks, brush clean dates, or aborted heat cycles. Page numbers are indicated in the upper right hand corner. Page 1 always contains the most recent failure.

LOCKOUT HISTORY	1
00/00/00	00:00
REASON	
> Exit	

The second line of the screen displays the date and time a failure occurs. The third line indicates the reason for a failure, or will indicate if a successful brush cleaning has occurred. Some failures occur with multiple reasons. When this occurs, a record will be generated for each reason.

Use the arrow keys to advance forward or move backward to view each screen.

System Information

The SYSTEM INFORMATION is displayed on three separate screens. The first screen contains the control and software version installed in the unit.

SOFTWARE VERSION
C712 / C713 UVC4
VERSION X X X
> Next

Touch the SEL key to advance to the next system information screen containing the software language version.

Language
V4.00 English
> Next

Touch the SEL key to advance to the third system information screen containing the model bill of material and unit serial number.

B.O.M. C71227C000
S/N K0000000
> Next

Pressing the SEL key again will return to the Menu screen.

Current Conditions

This screen provides the viscosity readings for the product when the unit is running, and the hopper and the freezing cylinder temperatures for the unit.

VISC	0.0	0.0
HOPPER	41.0	41.0
BARREL	41.0	41.0

Press the SEL or Menu key to return to the Menu screen.

Net Service Pin

The NET SERVICE PIN screen allows the manager or service technician to initialize a network connection for networking kitchens.

NET SERVICE PIN
ARE YOU SURE?
Yes
> No

Pressing the UP or DOWN key will move the arrow to "Yes" or "No". Pressing the SEL key with the arrow next to "No" will return to the Menu screen. Pressing the SEL key with the arrow next to "Yes" will connect to the network if a gateway card is connected. If "Yes" is selected, the unit will appear to "hang" until the memory is cleared and the defaults are loaded. The display may show the message "COMMUNICATIONS FAILURE" during this time.

Section 6

Operating Procedures

The C712 machine stores mix in a hopper. It has two 3.4 quart (3.2 liter) capacity freezing cylinders with a three spout door.

We begin our instructions at the point where we enter the store in the morning and find the parts disassembled and laid out to air dry from the previous night's cleaning.

These opening procedures will show you how to assemble these parts into the freezer, sanitize them, and prime the freezer with fresh mix in preparation to serve your first portion.

If you are disassembling the machine for the first time or need information to get to this starting point in our instructions, turn to page 33, "Disassembly", and start there.

Freezing Cylinder Assembly

Note: When lubricating parts, use an approved food grade lubricant (example: Taylor Lube).



MAKE SURE THE POWER SWITCH IS IN THE "OFF" POSITION! Failure to follow this instruction may result in severe personal injury from hazardous moving parts.

Step 1

Before installing the beater drive shaft, lubricate the groove on the beater drive shaft.

Step 2

Slide the beater drive shaft boot seal over the small end of the beater drive shaft and engage into the groove on the shaft.

Step 3

Heavily lubricate the inside portion of the boot seal and also lubricate the flat end of the boot seal that comes in contact with the rear shell bearing.

Step 4

Apply an even coat of lubricant to the shaft. DO NOT lubricate the hex end. (See Figure 10.)

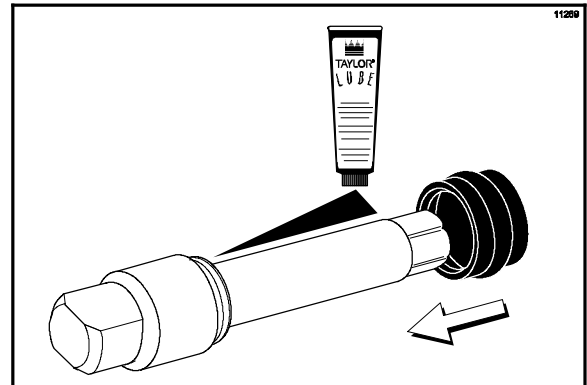

Figure 10

Note: To ensure the mix does not leak out of the back of the freezing cylinder, the middle section of the boot seal should be convex or extend out from the seal. If the middle section of the boot seal is concave or extending into the middle of the seal, turn the seal inside out.

Step 5

Insert the beater drive shaft through the rear shell bearing in the freezing cylinder and engage the hex end firmly into the drive coupling. (See Figure 11.)

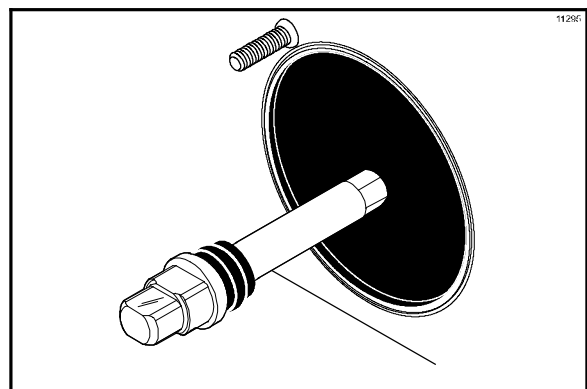

Figure 11



USE EXTREME CAUTION when handling the beater assembly. The scraper blades are very sharp and may cause injury.

Step 6

Before installing the beater assembly, check the scraper blades for any signs of wear or damage. If a scraper blade is nicked or worn, replace both blades.

Check the scraper blade clips to make sure they are not bent and the slot is even for the entire length of the clip. Replace any damaged clips. (See Figure 12.)

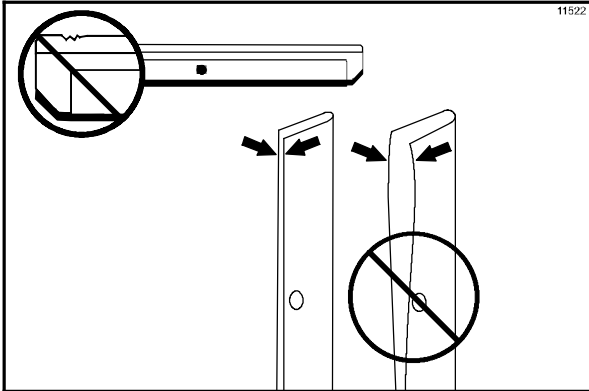

Figure 12

Step 7

If the blades and clips are in good condition, install the scraper blade clips over the scraper blades. Place the rear scraper blade over the rear holding pin on the beater. (See Figure 13.)

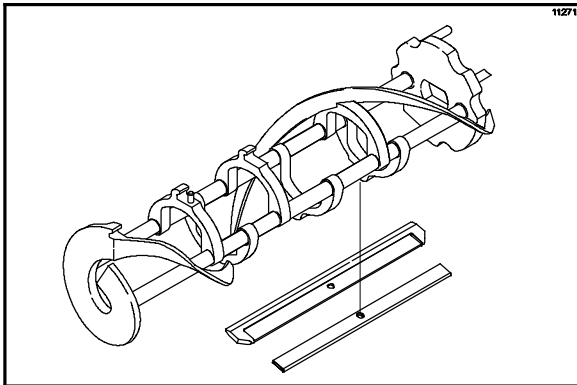

Figure 13

Note: Scraper blades should be replaced every 3 months.

Note: The hole on the scraper blade must fit securely over the pin to prevent costly damage.

Step 8

Holding the rear blade on the beater, slide it into the freezing cylinder halfway. Install the front scraper blade over the front holding pin. (See Figure 14.)

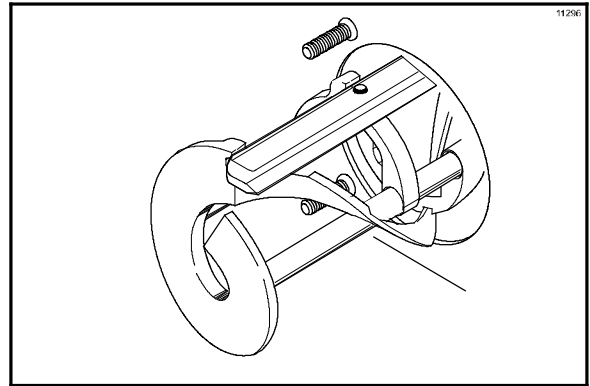

Figure 14

Step 9

Before installing the beater shoes, check the shoes for any nicks, cracks, or signs of wear. If any defects are present, replace the beater shoes.

Step 10

If the shoes are in good condition, install the beater shoes. (See Figure 15.)

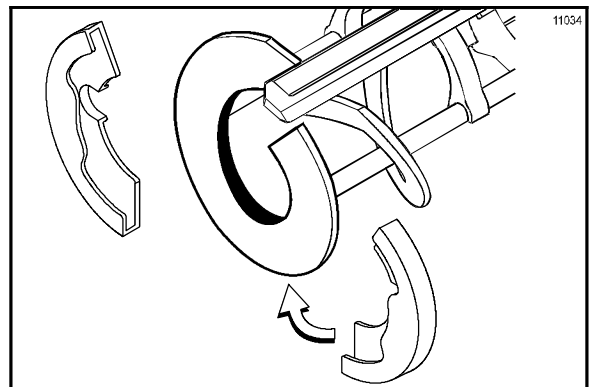

Figure 15

Step 11

Slide the beater assembly the rest of the way into the freezing cylinder.

Make sure the beater assembly is in position over the drive shaft by turning the beater slightly until the beater is properly seated. When in position, the beater will not protrude beyond the front of the freezing cylinder. (See Figure 16.)

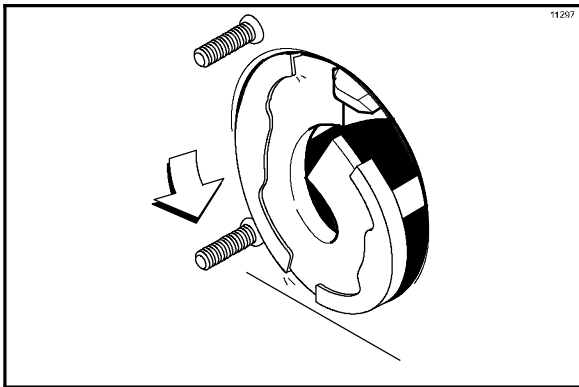

Figure 16

Repeat these steps for the other side of the machine.

Step 12

Before assembling the freezer door, check the following for any nicks, cracks, or signs of wear: door bearings, door gaskets, draw valves, o-rings, and all sides of the door assembly, including the inside of the draw valve bores. Replace any damaged parts.

Step 13

Place the door gaskets into the grooves on the back of the freezer door. (See Figure 17.)

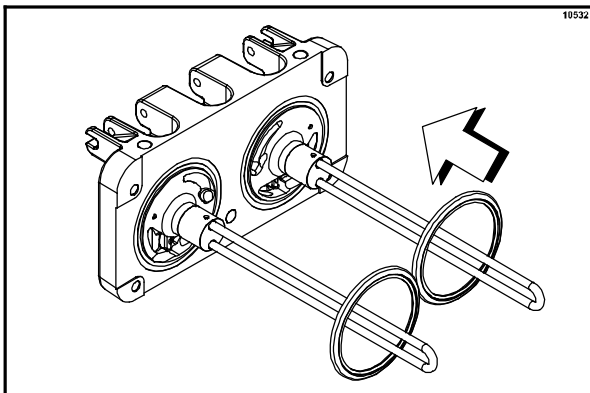

Figure 17

Slide the front bearings over the baffle rods. The flanged edges should be against the door. **DO NOT lubricate the gaskets or front bearings.**

Slide the two o-rings into the grooves on each prime plug. Apply an even coat of Taylor Lube to the o-rings and shafts. (See Figure 18.)

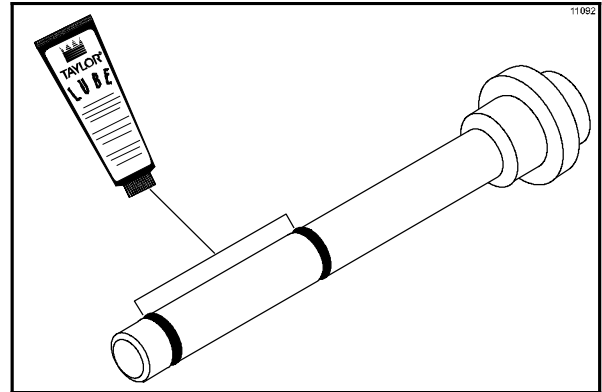

Figure 18

Step 14

Insert the prime plugs into the holes in the top of the freezer door, and push down. (See Figure 19.)

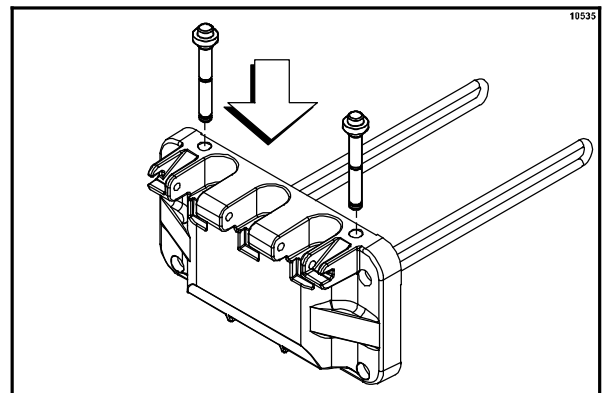

Figure 19

Step 15

To install the freezer door, insert the baffle rods through the beaters in the freezing cylinders. (See Figure 20.)

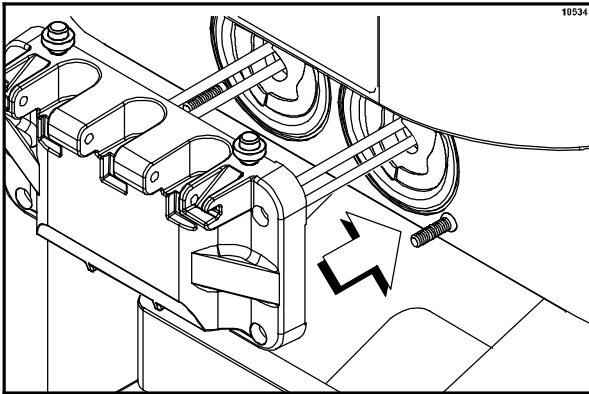

Figure 20

With the door seated on the freezer studs, install the handscrews. Use the long handscrews on the top and the short handscrews on the bottom. Tighten them equally in a criss-cross pattern to insure the door is snug.

Step 16

Slide the three o-rings into the grooves of each standard draw valve. Slide the H-ring and o-ring into the grooves of the center draw valve. Lubricate the H-ring and o-rings. (See Figure 21.)

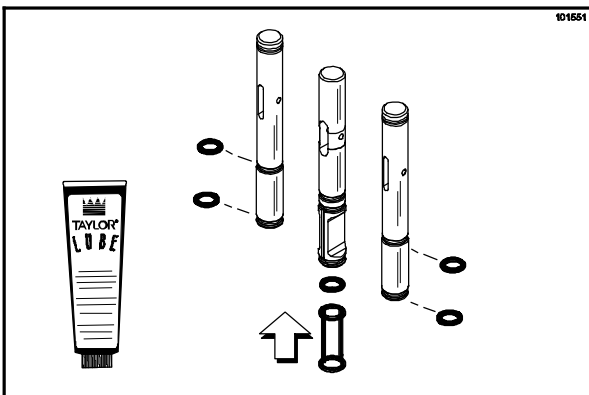

Figure 21

Step 17

Lubricate the inside of the freezer door spouts, top and bottom. (See Figure 22.)

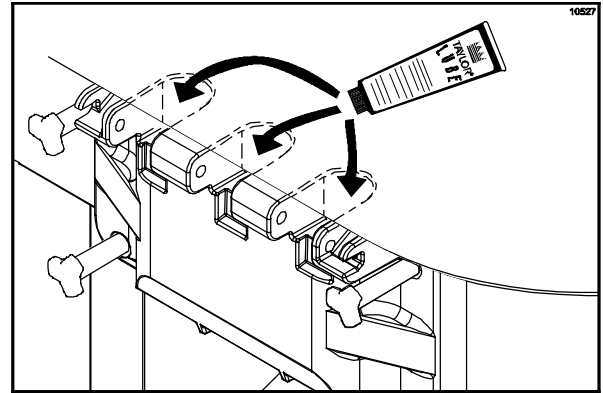

Figure 22

Step 18

Insert the draw valves from the bottom until the slot in each draw valve comes into view. (See Figure 23.)

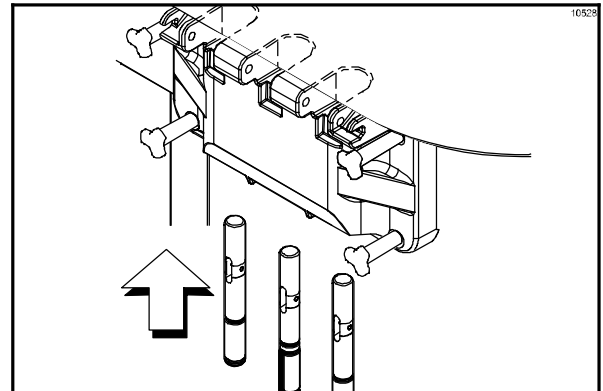

Figure 23

Step 19

Position each draw handle with the adjustment screw facing down. Slide the fork of each draw handle into the slot of each draw valve, starting from the right. (See Figure 24.)

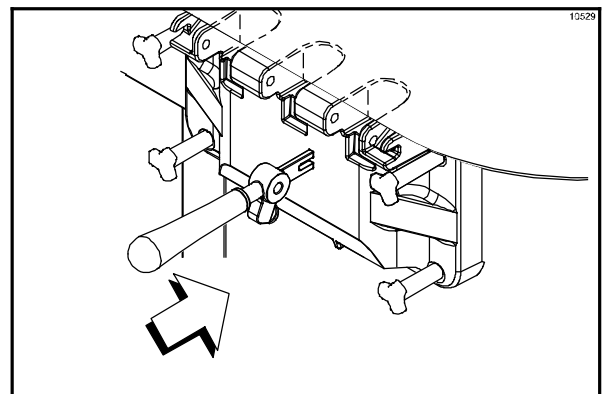

Figure 24

Step 20

Slide the pivot pin through the draw handles as the handles are inserted into the draw valves. (See Figure 25.)

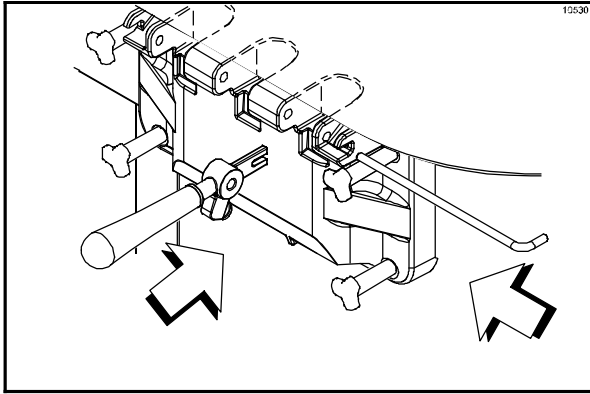

Figure 25

Note: This freezer features three adjustable draw handles to provide portion control, giving a better consistent quality to your product and controlling costs. The draw handle should be adjusted to provide a flow rate of 5 to 7-1/2 oz. (142 g. to 213 g.) of product by weight per 10 seconds.

To INCREASE the flow rate, tighten the screw. To DECREASE the flow rate, loosen the screw. (See Figure 26.)

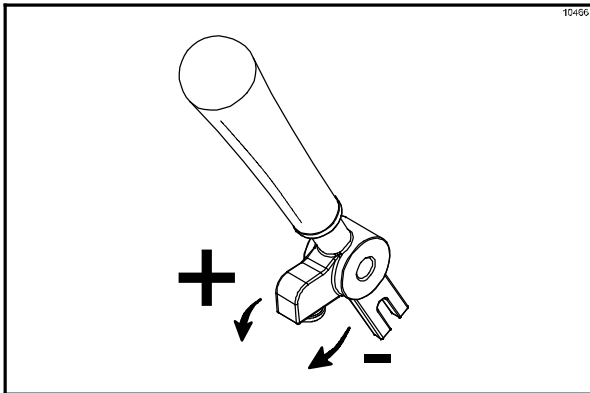

Figure 26

Step 21

Snap the design caps over the bottom of the door spouts. (See Figure 27.)

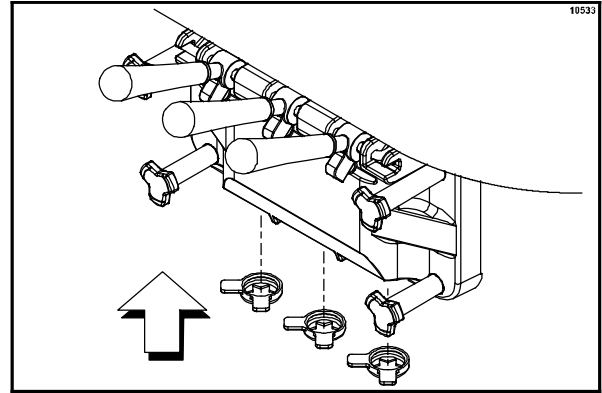

Figure 27

Step 22

Slide the two rear drip pans into the holes in the back panel. Slide the two drip pans into the holes in the side panels. (See Figure 28.)

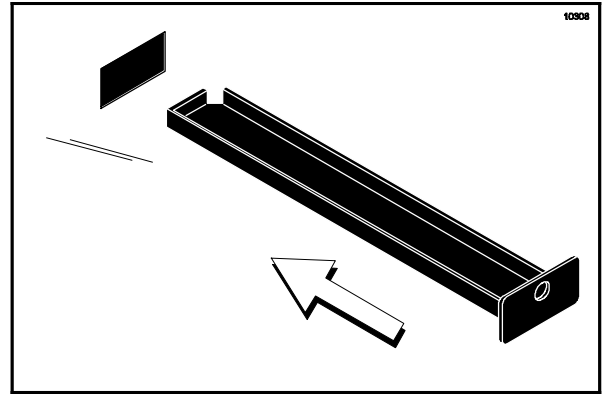

Figure 28

Step 23

Install the front drip tray and splash shield under the door spouts. (See Figure 29.)

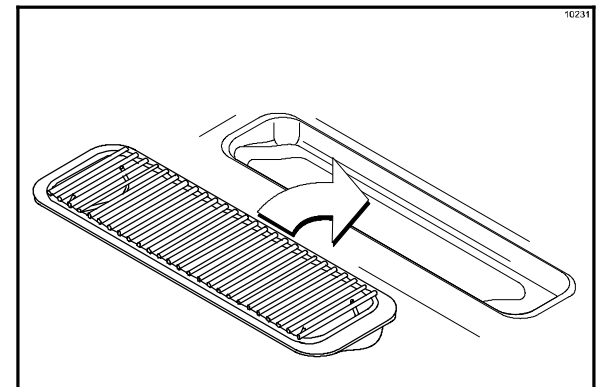

Figure 29

Mix Pump Assembly

Step 1

Inspect the rubber and plastic pump parts. The o-rings, check ring, and gasket must be in 100% good condition for the pump and entire machine to operate properly. They cannot properly serve their intended function if nicks, cuts, or holes in the material are present.

Inspect the plastic pump parts for cracks, wear, and de-lamination of plastic.

Replace any defective parts immediately and discard the old.

Step 2

Assemble the piston. Slide the red o-ring into the groove of the piston. DO NOT lubricate the o-ring. (See Figure 30.)

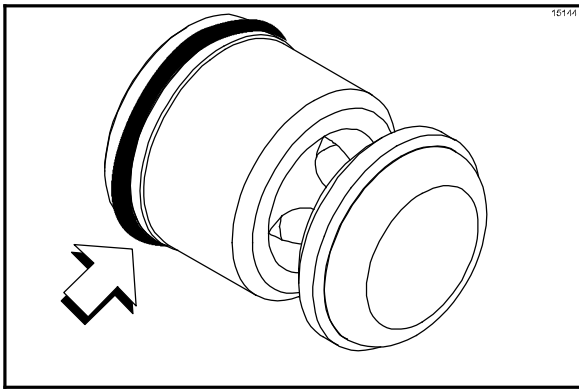

Figure 30

Step 3

Apply a thin layer of lubricant to the inside of the pump cylinder at the retaining pin hole end. (See Figure 31.)

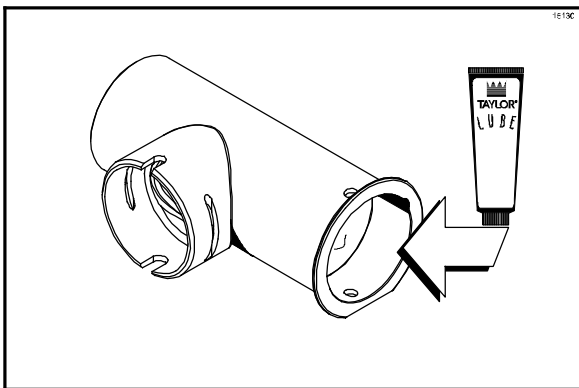

Figure 31

Step 4

Insert the piston into the retaining pin hole end of the pump cylinder. (See Figure 32.)

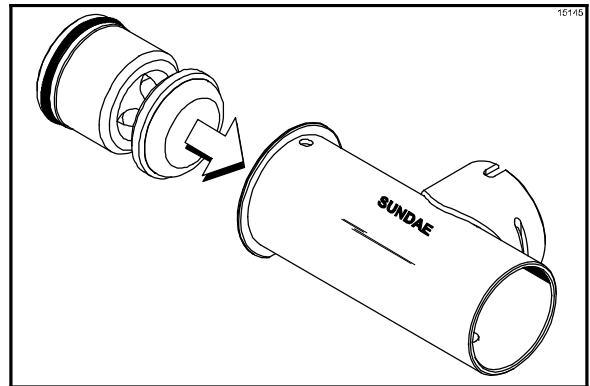

Figure 32

Step 5

Assemble the valve cap. Slide the o-ring into the groove of the valve cap. DO NOT lubricate the o-ring. (See Figure 33.)

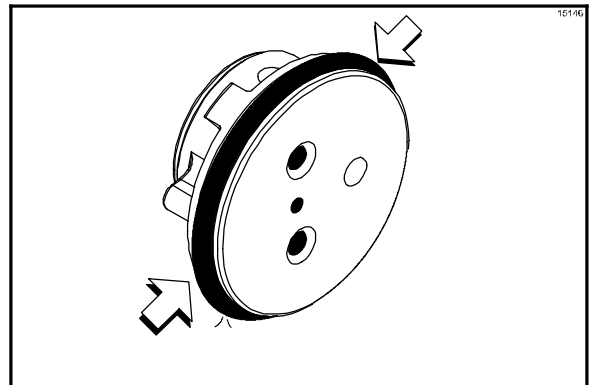

Figure 33

Step 6

Slide the pump valve gasket into the holes on the cap. DO NOT lubricate the gasket. (See Figure 34.)

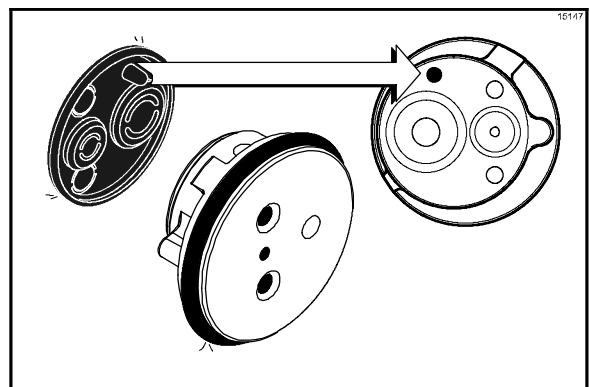

Figure 34

Step 7

Insert the valve body cap into the hole in the mix inlet adapter. (See Figure 35.)

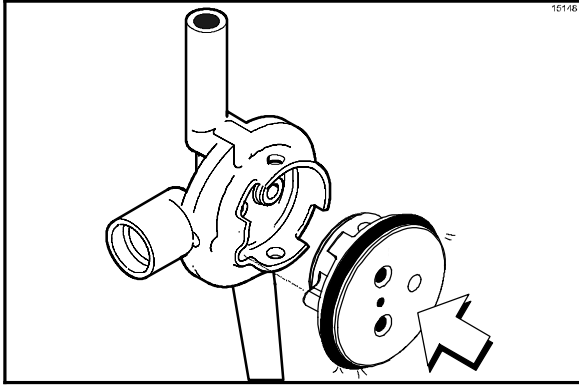

Figure 35

Step 8

Insert the mix inlet assembly into the pump cylinder. (See Figure 36.)

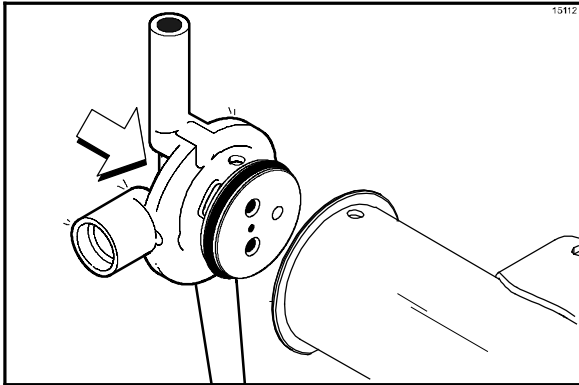

Figure 36

The adapter must be positioned into the notch located at the end of the pump cylinder.

Step 9

Secure the pump parts in position by sliding the retaining pin through the cross holes located at one end of the pump cylinder. (See Figure 37.)

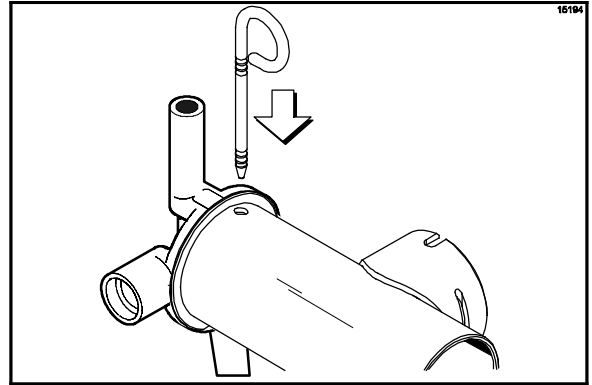

Figure 37

Note: The head of the retaining pin should be located at the top of the pump when installed.

Step 10

Assemble the feed tube assembly. Slide the check ring into the groove of the feed tube. (See Figure 38.)

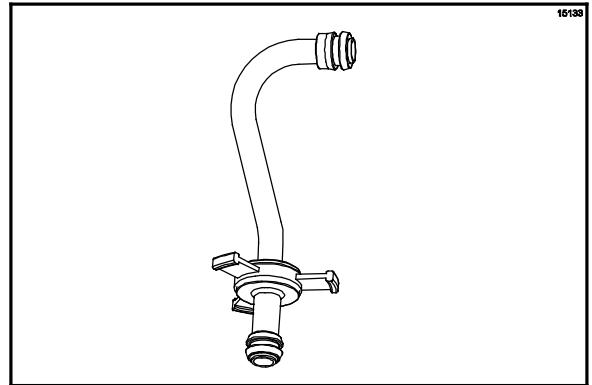

Figure 38

Step 11

Install one red o-ring on each end of the mix feed tube, and thoroughly lubricate. (See Figure 39.)

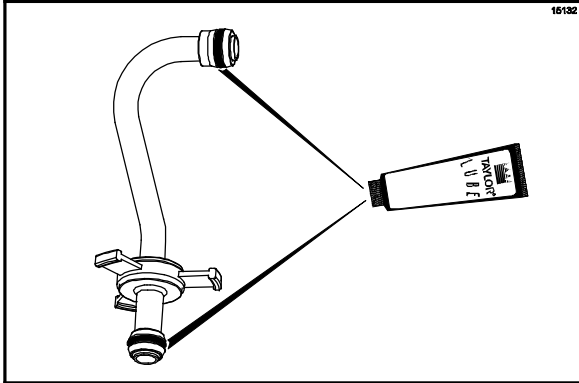

Figure 39

Step 12

Lay the pump assembly, pump clip, cotter pin, and mix feed tube in the bottom of the mix hopper for sanitizing.

Step 13

Slide the large black o-ring and the two smaller black o-rings into the grooves on the drive shaft. Thoroughly lubricate the o-rings and shaft. DO NOT lubricate the hex end of the shaft. (See Figure 40.)

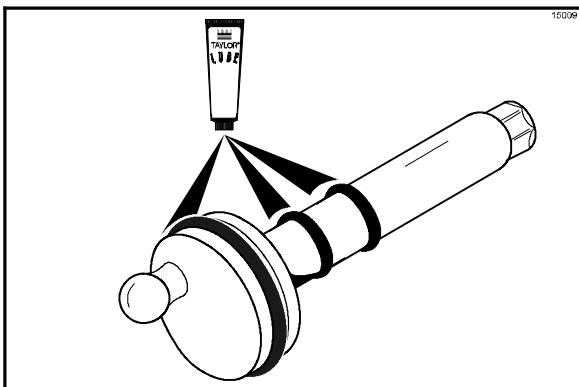

Figure 40

Step 14

Install the hex end of the drive shaft into the drive hub at the rear wall of the mix hopper. (See Figure 41.)

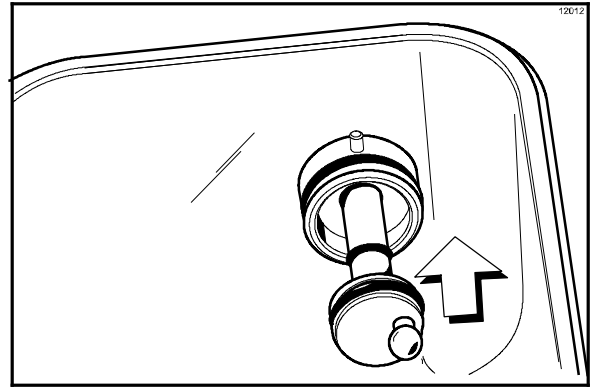

Figure 41

Note: For ease in installing the pump, position the ball crank of the drive shaft in the 3 o'clock position.

Repeat these steps for the other side of the machine.

Sanitizing

Step 1

Prepare a pail of approved 100 PPM sanitizing solution (examples: 2-1/2 gal. [9.5 liters] of Kay-5® or 2 gal. [7.6 liters] of Stera-Sheen®). USE WARM WATER AND FOLLOW THE MANUFACTURER'S SPECIFICATIONS.

Step 2

Pour sanitizing solution over all the parts in the bottom of the mix hopper and allow it to flow into the freezing cylinder. (See Figure 42.)

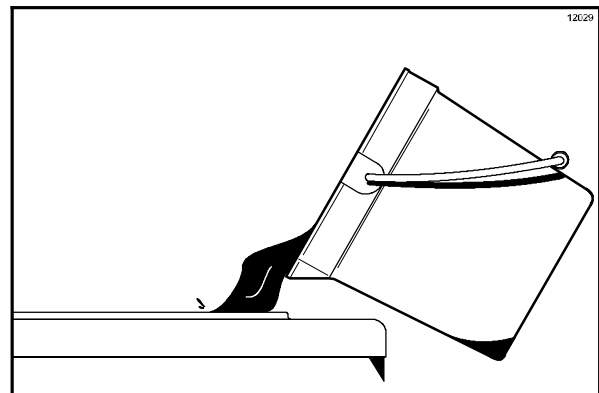

Figure 42

Note: You have just sanitized the mix hopper and parts; therefore, be sure your hands are clean and sanitized before going on in these instructions.

Step 3

While the solution is flowing into the freezing cylinder, take particular care to brush-clean the mix level sensing probe, the mix hopper, the mix inlet hole, the air/mix pump, the pump clip, the mix feed tube, and the cotter pin.

Step 4

Install the pump assembly at the rear of the mix hopper. To position the pump on the drive hub, align the drive hole in the piston with the drive crank of the drive shaft. Secure the pump in place by slipping the pump clip over the collar of the pump, making sure the clip fits into the grooves in the collar. (See Figure 43.)

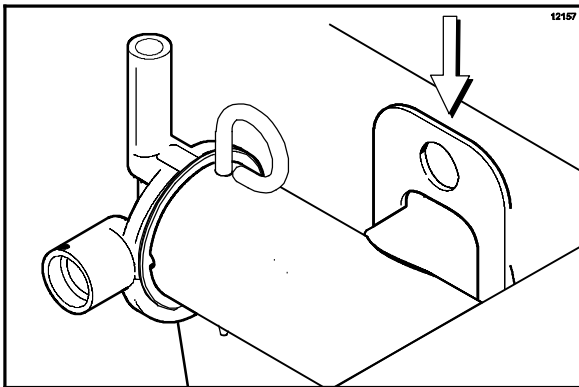

Figure 43

Step 5



Install the pump end of the mix feed tube and secure with the cotter pin. Failure to follow this instruction could result in sanitizer spraying on the operator. (See Figure 44.)

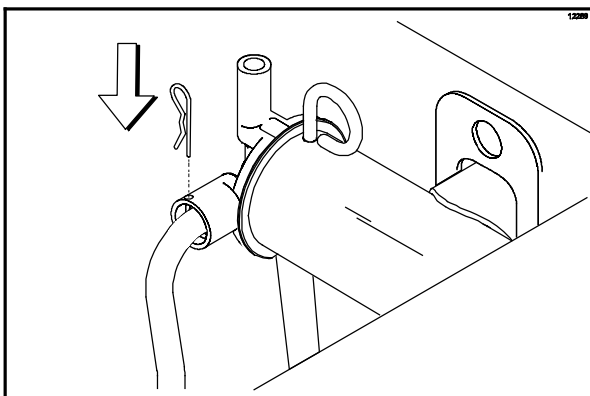

Figure 44

Step 6

Prepare another pail of approved 100 PPM sanitizing solution (examples: 2-1/2 gal. [9.5 liters] of Kay-5® or 2 gal. [7.6 liters] of Stera-Sheen®). **USE WARM WATER AND FOLLOW THE MANUFACTURER'S SPECIFICATIONS.**

Step 7

Pour the sanitizing solution into the mix hopper.

Step 8

Brush the exposed sides of the hopper.

Step 9

Place the power switch in the ON position.

Step 10

Touch the WASH symbol . This will cause the sanitizing solution in the freezing cylinder to be agitated. Wait at least 5 minutes before proceeding with these instructions.



Step 11

With an empty pail beneath the door spouts, raise the prime plug and touch the PUMP symbol .

Step 12

When a steady stream of sanitizing solution is flowing from the prime plug opening in the bottom of the freezer door, open the draw valve. Momentarily open the center draw valve to sanitize the center door spout. Draw off the remaining sanitizing solution.

Step 13

Once the sanitizer stops flowing from the door spout, touch the WASH and PUMP symbols   and close the draw valve.

IMPORTANT: The unit must NOT be placed in AUTO until all sanitizing solution has been removed from the freezing cylinder and proper priming procedures have been completed. Failure to follow this instruction may result in damage to the freezing cylinder.

Repeat these steps for the other side of the machine.

Note: Be sure your hands are clean and sanitized before going on in these instructions.

Priming

Note: Use only FRESH MIX when priming the freezer.

Step 1

Place an empty pail beneath the door spouts. With the prime plug in the UP position, pour 2-1/2 gallons (9.5 liters) of FRESH mix into the mix hopper and allow it to flow into the freezing cylinder.

Step 2

Open the draw valve to remove all sanitizing solution. When only fresh mix is flowing, close the draw valve.

Step 3

Once a steady stream of mix starts to flow from the prime plug opening in the bottom of the freezer door, push the prime plug down.

IMPORTANT: Failure to remove all sanitizing solution may result in damage to the freezing cylinder.

Step 4

When mix stops bubbling down into the freezing cylinder, remove the cotter pin from the outlet fitting of the mix pump. Insert the outlet end of the mix feed tube into the mix inlet hole in the mix hopper. Place the inlet end of the mix feed tube into the outlet fitting of the mix pump. Secure with cotter pin.

Step 5

Select the AUTO symbol ❄️.

Note: The brush clean counter will start at this time.

Step 6

Fill the hopper with fresh mix and place the mix hopper cover in position.

Repeat these steps for the other side of the machine.

Manual Brush Cleaning

This Procedure Must Be Completed Every Day



To disassemble the Model C712, the following items will be needed:

- Two cleaning and sanitizing pails
- Sanitizer/Cleaner
- Necessary brushes (provided with freezer)
- Single service towels

Draining Product From The Freezing Cylinder

Step 1

With a pail beneath the door spouts, open the draw valve. Touch the WASH and PUMP symbols 🚰 🚰.

IMPORTANT! DO NOT allow the pump to keep running when the draw valve is closed. Excessive pressure will build up causing product to spurt out when the draw valve is opened.

Drain the product from the freezing cylinder and the mix hopper.

Step 2

When the flow of product stops, touch the WASH and PUMP symbols 🚰 🚰, cancelling the WASH and PUMP modes. Close the draw valve and push the prime plug down.

Step 3

Remove the cotter pin, mix feed tube, pump clip and the assembled air/mix pump.

Repeat these steps for the other side of the machine.

Rinsing

Step 1

Pour two gallons (7.6 liters) of cool, clean water into the mix hopper. With the white hopper brush, scrub the mix hopper and the mix level sensing probe. Using the double ended brush, brush clean the mix inlet hole. (See Figure 45.)

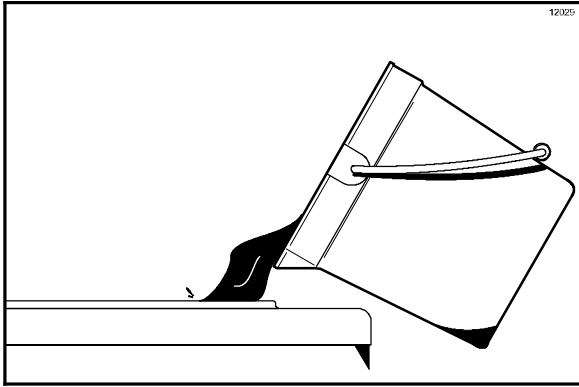



Figure 45

Note: Do not brush clean the mix inlet hole while the machine is in the WASH mode.

Step 2

With a pail beneath the door spouts, raise the prime plug and touch the WASH symbol . (See Figure 46.)

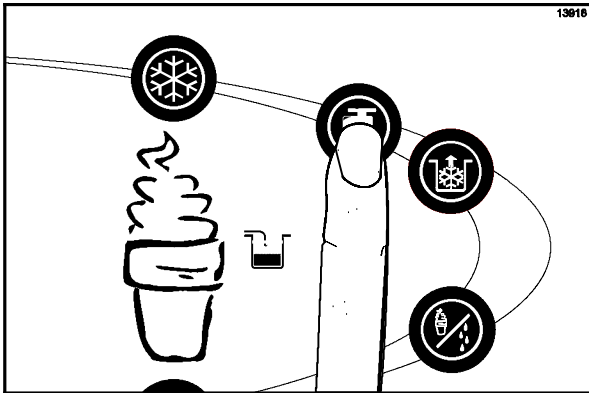



Figure 46

Step 3

When a steady stream of rinse water is flowing from the prime plug opening in the bottom of the freezer door, open the draw valve. Drain all the rinse water from the door spout. Close the draw valve and push the prime plug down.

Step 4

Touch the WASH symbol,  cancelling the Wash mode.

Step 5

Repeat this procedure using clean, warm water, until the water being discharged is clear.

Repeat these steps for the other side of the machine.

Hopper Cleaning

Step 1

Prepare a pail of approved 100 PPM cleaning solution (examples: 2-1/2 gal. [9.5 liters] of Kay-5® or 2 gal. [7.6 liters] of Stera-Sheen®). USE WARM WATER AND FOLLOW THE MANUFACTURER'S SPECIFICATIONS.

Step 2

With the prime plug pushed down, pour the cleaning solution into the hopper. Allow the solution to flow into the freezing cylinder.

Step 3

Using the white hopper brush, clean the mix hopper and the mix level sensing probes. Using the double ended brush, clean the mix inlet hole. (**Note:** Do not brush clean the mix inlet hole while the machine is in the Wash mode.)

Step 4

Touch the WASH symbol . This will cause the cleaning solution in the freezing cylinder to come in contact with all areas of the freezing cylinder. Wait at least 5 minutes before proceeding with these instructions. (See Figure 47.)

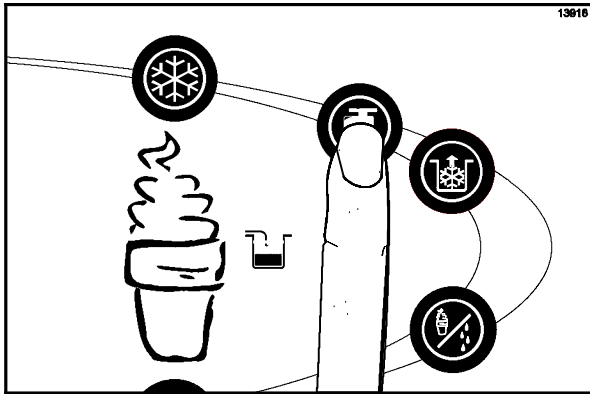

Figure 47

Step 5

Place an empty pail beneath the door spouts.

Step 6

Raise the prime plug.

Step 7

When a steady stream of cleaning solution is flowing from the prime plug opening in the bottom of the freezer door, open the draw valve. Draw off all the solution.

Step 8

Once the cleaning solution stops flowing from the door spout, close the draw valve and the prime plug.

Step 9

Touch the WASH symbol , cancelling the Wash mode.

Repeat these steps on the other side of the machine.

Disassembly



MAKE SURE THE POWER SWITCH IS IN THE "OFF" POSITION! Failure to follow this instruction may result in severe personal injury from hazardous moving parts.

Step 1

Remove the handscrews, freezer door, beater and scraper blades, and drive shaft with drive shaft seal from the freezing cylinder.

Step 2

Remove the scraper blade clips from the scraper blades.

Step 3

Remove the drive shaft seal from each drive shaft.

Step 4

From each pump cylinder, remove the retaining pin, mix inlet adaptor, valve cap, pump gasket, and the piston. Remove the o-ring from the piston and valve cap.

Step 5

Remove the freezer door gaskets, front bearings, pivot pin, draw handles, draw valves, prime plugs, and design caps. Remove the o-rings from the draw valves.

Step 6

Remove the pump drive shafts from the drive hubs in the rear wall of the mix hoppers. (See Figure 48.)

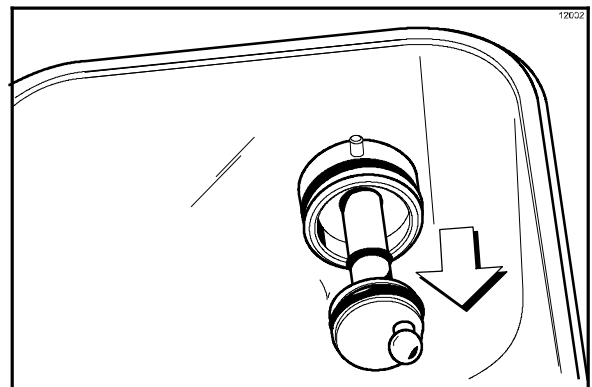

Figure 48

Step 7

Remove the two small o-rings and one large o-ring from each pump drive shaft.

Step 8

Remove the front drip tray and splash shield.

Step 9

Remove all drip pans. Take them to the sink for cleaning. (See Figure 49.)

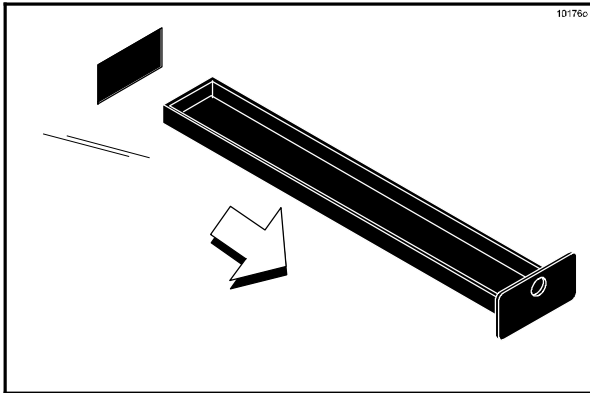

Figure 49

Note: If the drip pans are filled with an excessive amount of mix, it is an indication that the drive shaft seal(s), or o-ring(s) should be replaced or properly lubricated.

Brush Cleaning

Step 1

Prepare a sink with an approved 100 PPM cleaning/sanitizing solution (examples: Kay-5® or Stera-Sheen®). USE WARM WATER AND FOLLOW THE MANUFACTURER'S SPECIFICATIONS. Make sure all brushes provided with the freezer are available for brush cleaning.

Step 2

Thoroughly brush clean all disassembled parts in the cleaning solution, making sure all lubricant and mix film is removed. Be sure to brush all surfaces and holes, especially the holes in the pump components and the draw valve holes in the freezer door.

Rinse all parts with clean, warm water. Place the parts on a clean, dry surface to air dry overnight.

Step 3

Return to the freezer with a small amount of cleaning solution. Using the black brush, clean the rear shell bearing at the back of each freezing cylinder. (See Figure 50.)

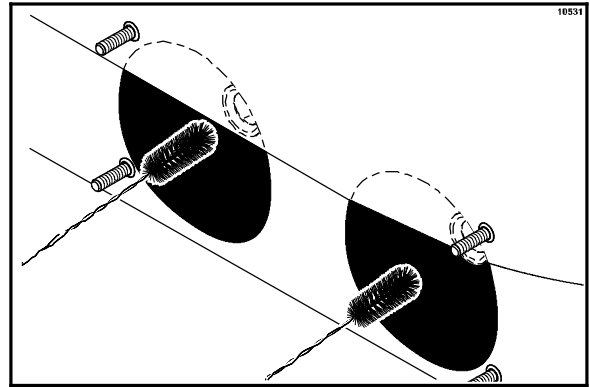

Figure 50

Step 4

Using the black brush, clean the drive hub opening in the rear wall of each mix hopper. (See Figure 51.)

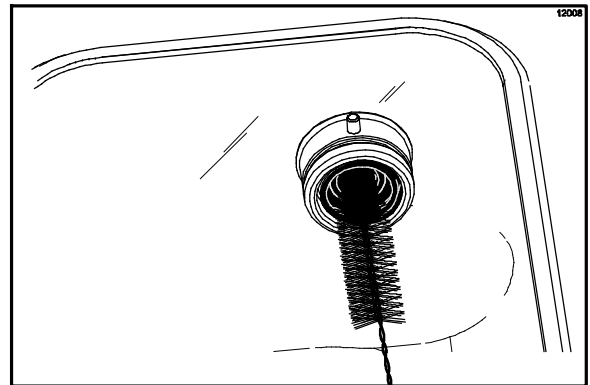

Figure 51

Step 5

Wipe all exterior surfaces of the freezer with a clean, sanitized towel.

Note: The brush clean counter will reset to zero at this time.

Section 7 Important: Operator Checklist

During Cleaning and Sanitizing



ALWAYS FOLLOW LOCAL HEALTH CODES.

Cleaning and sanitizing schedules are governed by federal, state, or local regulatory agencies, and must be followed accordingly. If the unit has a “Standby mode”, it must not be used in lieu of proper cleaning and sanitizing procedures and frequencies set forth by the ruling health authority. The following check points should be stressed during the cleaning and sanitizing operations.



CLEANING AND SANITIZING MUST BE PERFORMED DAILY.

Troubleshooting Bacterial Count

- 1. Thoroughly clean and sanitize the machine regularly, including complete disassembly and brush cleaning.
- 2. Use all brushes supplied for thorough cleaning. The brushes are specially designed to reach all mix passageways.
- 3. Use the white bristle brush to clean the mix inlet hole which extends from the mix hopper down to the rear of the freezing cylinder.
- 4. Use the black bristle brush to thoroughly clean the rear shell bearing located at the rear of the freezing cylinder and the drive hub opening in the rear wall of the mix hopper. Be sure there is a generous amount of cleaning solution on the brush.
- 5. Properly prepare the cleaning and sanitizing solutions. Read and follow the label directions carefully. Too strong of a solution may damage the parts and too weak of a solution will not do an adequate job of cleaning or sanitizing.
- 6. The temperature of mix in the mix hopper and walk-in cooler should be below 40°F (4.4°C).

- 7. Discard remaining mix from the freezer during “Cleaning Procedures”.

Regular Maintenance Checks

- 1. Replace scraper blades that are nicked or damaged. Before installing the beater assembly, be certain that scraper blades are properly attached to the helix.
- 2. Check the rear shell bearing for signs of wear (excessive mix leakage in rear drip pan) and be certain it is properly cleaned.
- 3. Using a screwdriver and cloth towel, keep the rear shell bearing and the female hex drive socket clean and free of lubricant and mix deposits.
- 4. Dispose of o-rings and seals if they are worn, torn, or fit too loosely, and replace with new ones.
- 5. Follow all lubricating procedures as outlined in “Assembly”.
- 6. If your machine is air cooled, check the condensers for accumulation of dirt and lint. Dirty condensers will reduce the efficiency and capacity of the machine. Condensers should be cleaned **monthly** with a soft brush. **Never** use screwdrivers or other metal probes to clean between the fins.
Note: For machines equipped with an air filter, it will be necessary to vacuum clean the filters on a monthly schedule.



Caution: Always disconnect electrical power prior to cleaning the condenser. Failure to follow this instruction may result in electrocution.

- 7. If your machine is water cooled, check the water lines for kinks or leaks. Kinks can occur when the machine is moved back and forth for cleaning or maintenance purposes. Deteriorated or cracked water lines should be replaced only by an authorized Taylor distributor.

Winter Storage

If the place of business is to be closed during the winter months, it is important to protect the freezer by following certain precautions, particularly if the building is subject to freezing conditions.

Disconnect the freezer from the main power source to prevent possible electrical damage.

On water cooled freezers, disconnect the water supply. Relieve pressure on the spring in the water valve. Use air pressure on the outlet side to blow out any water remaining in the condenser. **This is extremely important.** Failure to follow this procedure may cause severe and costly damage to the refrigeration system.

Your local Taylor Distributor can perform this winter storage service for you.

Wrap detachable parts of the freezer such as beater, blades, drive shaft, and freezer door, and place them in a protected dry place. Rubber trim parts and gaskets can be protected by wrapping them with moisture-proof paper. All parts should be thoroughly cleaned of dried mix or lubrication which attract mice and other vermin.

It is recommended that an authorized service technician perform winter storage draining, to insure all water has been removed. This will guard against freezing and rupturing of the components.

Section 8

Troubleshooting Guide

PROBLEM	PROBABLE CAUSE	REMEDY	PAGE REF.
1. No product is being dispensed.	a. Low on mix. The MIX OUT light is on.	a. Add mix to the mix hopper. Return to AUTO mode.	31
	b. The power switch is in the OFF position.	b. Place the power switch to ON and select AUTO.	30
	c. Machine not in AUTO mode.	c. Select AUTO and allow machine to cycle off before drawing product.	31
	d. Beater motor is out on reset. The BEATER OVERLOAD message displayed.	d. Turn the machine off. Press the reset button. Restart the machine in AUTO.	---
	e. The pump motor is not running in the AUTO mode.	e. Push the pump reset button. Check pump motor is operating when the draw valve is raised.	15
	f. Freeze-up in mix inlet hole.	f. Call an authorized service technician.	---
	g. The mix pump ball crank is broken.	g. Call an authorized service technician.	---
	h. Feed tube or check ring not properly installed.	h. Make sure feed tube and rubber check ring are properly installed.	28, 31
	i. Butterfat buildup in the pump.	i. Carefully remove the mix pump, clean and reinstall.	33
2. The product is too soft.	a. Draw rate is set too fast.	a. Adjust draw rate of 5 to 7 1/2 oz. (142 g. to 213 g.) of product by weight in 10 seconds.	26

PROBLEM	PROBABLE CAUSE	REMEDY	PAGE REF.
3. The product is too thick.	a. Freezing cylinder not primed correctly.	a. Drain the freezing cylinder and reprime the machine.	31
	b. Air/mix pump incorrectly assembled.	b. Follow assembly procedures carefully.	27
	c. The viscosity control is set too cold.	c. Call an authorized service technician.	---
	d. Freeze-up in mix inlet hole.	d. Call an authorized service technician.	---
4. The mix in the hopper is too warm.	a. Hopper cover is not in position.	a. Clean and sanitize hopper cover and place in position.	31
	b. The hopper temperature is out of adjustment.	b. Call an authorized service technician.	---
5. The mix in the hopper is too cold.	a. The hopper temperature is out of adjustment.	a. Call an authorized service technician.	---
6. Mix Low and Mix Out probes are not functioning.	a. Milkstone build-up in the hopper.	a. Clean hoppers thoroughly.	34
7. Product is collecting on top of the freezer door.	a. The top o-ring on draw valve is improperly lubricated or worn.	a. Lubricate properly or replace the o-ring.	25
8. Excessive mix leakage from the bottom of door spout.	a. Bottom o-ring on draw valve is improperly lubricated or worn.	a. Lubricate properly or replace the o-ring.	25
9. Excessive mix leakage into the long drip pan.	a. The seal on drive shaft is improperly lubricated or worn.	a. Lubricate properly or replace the seal.	22
	b. The seal is installed inside-out on the drive shaft.	b. Install correctly.	22
	c. Inadequate lubrication of the drive shaft.	c. Lubricate properly.	22
	d. The drive shaft and beater assembly work forward.	d. Call an authorized service technician.	---
	e. Worn rear shell bearing.	e. Call an authorized service technician.	---
	f. Gear box out of alignment.	f. Call an authorized service technician.	---

PROBLEM	PROBABLE CAUSE	REMEDY	PAGE REF.
10. The drive shaft is stuck in the drive coupling.	a. Mix and lubricant collected in drive coupling.	a. Brush clean the rear shell bearing area regularly.	34
	b. Rounded corners of drive shaft, drive coupling, or both.	b. Call an authorized service technician.	---
	c. Gear box is out of alignment.	c. Call an authorized service technician.	---
11. The freezing cylinder walls are scored.	a. Missing or worn front bearing and beater shoes.	a. Install or replace the front bearing and beater shoes.	23, 24
	b. Scraper blades and/or clips are damaged.	b. Replace scraper blades and/or clips.	23
	c. Unit was placed in AUTO before all sanitizing solution was removed from freezing cylinder.	c. Place unit in AUTO only after priming is complete and all sanitizing solution is removed.	30, 31
	d. Broken freezer door baffle rod.	d. Replace freezer door.	24
	e. Broken beater pins.	e. Replace beater assembly.	23
	f. Beater assembly is bent.	f. Replace beater assembly.	23
	g. Gear box is out of alignment.	g. Call an authorized service technician.	---
12. The product makes a popping sound when drawn.	a. Draw rate is set too fast.	a. Adjust draw rate of 5 to 7 1/2 oz. (142 g. to 213 g.) of product by weight in 10 seconds.	26
	b. Pump assembled incorrectly.	b. Assemble and lubricate according to instructions in this manual.	27
	c. Freezing cylinder not primed correctly.	c. Drain the freezing cylinder and reprime the machine.	31
13. No control panel functions with power switch ON.	a. Machine is unplugged.	a. Plug into wall receptacle.	---
	b. Circuit breaker OFF or blown fuse.	b. Turn the breaker ON or replace the fuse.	---

Section 9

Parts Replacement Schedule

PART DESCRIPTION	EVERY 3 MONTHS	EVERY 6 MONTHS	ANNUALLY
Scraper Blade	X		
Drive Shaft Seal	X		
Freezer Door Gasket	X		
Front Bearing	X		
Front Beater Shoes	X		
Draw Valve O-Ring	X		
Mix Feed Tube O-Ring	X		
Pump O-Ring	X		
Prime Plug O-Ring	X		
Pump Valve Gasket	X		
Mix Feed Tube Check Ring	X		
Pump Drive Shaft O-Ring	X		
White Bristle Brush, 3" x 7"		Inspect & Replace if Necessary	Minimum
White Bristle Brush, 3" x 1/2"		Inspect & Replace if Necessary	Minimum
Black Bristle Brush, 1" x 2"		Inspect & Replace if Necessary	Minimum
Double-Ended Brush		Inspect & Replace if Necessary	Minimum
Brush Set (3)		Inspect & Replace if Necessary	Minimum

Section 10 Limited Warranty on Equipment

TAYLOR COMPANY LIMITED WARRANTY ON FREEZERS

Taylor Company, a division of Carrier Commercial Refrigeration, Inc. (“Taylor”) is pleased to provide this limited warranty on new Taylor-branded freezer equipment available from Taylor to the market generally (the “Product”) to the original purchaser only.

LIMITED WARRANTY

Taylor warrants the Product against failure due to defect in materials or workmanship under normal use and service as follows. All warranty periods begin on the date of original Product installation. If a part fails due to defect during the applicable warranty period, Taylor, through an authorized Taylor distributor or service agency, will provide a new or re-manufactured part, at Taylor’s option, to replace the failed defective part at no charge for the part. Except as otherwise stated herein, these are Taylor’s exclusive obligations under this limited warranty for a Product failure. This limited warranty is subject to all provisions, conditions, limitations and exclusions listed below and on the reverse (if any) of this document.

Product	Part	Limited Warranty Period
Soft Serve	Insulated shell assembly	Five (5) years
Frozen Yogurt Shakes	Refrigeration compressor (except service valve)	Five (5) years
Smoothies	Beater motors	Two (2) years
Frozen Beverage	Beater drive gear	Two (2) years
Batch Desserts	Printed circuit boards and Softech controls beginning with serial number H8024200	Two (2) years
	Parts not otherwise listed in this table or excluded below	One (1) year

LIMITED WARRANTY CONDITIONS

1. If the date of original installation of the Product cannot be verified, then the limited warranty period begins ninety (90) days from the date of Product manufacture (as indicated by the Product serial number). Proof of purchase may be required at time of service.
2. This limited warranty is valid only if the Product is installed and all required service work on the Product is performed by an authorized Taylor distributor or service agency, and only if genuine, new Taylor parts are used.
3. Installation, use, care, and maintenance must be normal and in accordance with all instructions contained in the Taylor Operator’s Manual.
4. Defective parts must be returned to the authorized Taylor distributor or service agency for credit.
5. The use of any refrigerant other than that specified on the Product’s data label will void this limited warranty.

LIMITED WARRANTY EXCEPTIONS

This limited warranty does **not** cover:

1. Labor or other costs incurred for diagnosing, repairing, removing, installing, shipping, servicing or handling of defective parts, replacement parts, or new Products.
2. Normal maintenance, cleaning and lubrication as outlined in the Taylor Operator’s Manual, including cleaning of condensers.

3. Replacement of wear items designated as Class "000" parts in the Taylor Operator's Manual.
4. External hoses, electrical power supplies, and machine grounding.
5. Parts not supplied or designated by Taylor, or damages resulting from their use.
6. Return trips or waiting time required because a service technician is prevented from beginning warranty service work promptly upon arrival.
7. Failure, damage or repairs due to faulty installation, misapplication, abuse, no or improper servicing, unauthorized alteration or improper operation or use as indicated in the Taylor Operator's Manual, including but not limited to the failure to use proper assembly and cleaning techniques, tools, or approved cleaning supplies.
8. Failure, damage or repairs due to theft, vandalism, wind, rain, flood, high water, water, lightning, earthquake or any other natural disaster, fire, corrosive environments, insect or rodent infestation, or other casualty, accident or condition beyond the reasonable control of Taylor; operation above or below the electrical or water supply specification of the Product; or components repaired or altered in any way so as, in the judgment of the Manufacturer, to adversely affect performance, or normal wear or deterioration.
9. Any Product purchased over the Internet.
10. Failure to start due to voltage conditions, blown fuses, open circuit breakers, or damages due to the inadequacy or interruption of electrical service.
11. Electricity or fuel costs, or increases in electricity or fuel costs from any reason whatsoever.
12. Damages resulting from the use of any refrigerant other than that specified on the Product's data label will void this limited warranty.
13. Any cost to replace, refill or dispose of refrigerant, including the cost of refrigerant.
14. **ANY SPECIAL, INDIRECT OR CONSEQUENTIAL PROPERTY OR COMMERCIAL DAMAGE OF ANY NATURE WHATSOEVER.** Some jurisdictions do not allow the exclusion of incidental or consequential damages, so this limitation may not apply to you.

This limited warranty gives you specific legal rights, and you may also have other rights which vary from jurisdiction to jurisdiction.

LIMITATION OF WARRANTY

THIS LIMITED WARRANTY IS EXCLUSIVE AND IS IN LIEU OF ALL OTHER WARRANTIES, CONDITIONS AND/OR REMEDIES UNDER THE LAW, INCLUDING ANY IMPLIED WARRANTIES OR CONDITIONS OF MERCHANTABILITY OR FITNESS FOR A PARTICULAR PURPOSE. THE ORIGINAL OWNER'S SOLE REMEDY WITH RESPECT TO ANY PRODUCTS SHALL BE REPAIR OR REPLACEMENT OF DEFECTIVE COMPONENTS UNDER THE TERMS OF THIS LIMITED WARRANTY. ALL RIGHTS TO CONSEQUENTIAL OR INCIDENTAL DAMAGES (INCLUDING CLAIMS FOR LOST SALES, LOST PROFITS, PRODUCT LOSS, PROPERTY DAMAGES OR SERVICE EXPENSES) ARE EXPRESSLY EXCLUDED. THE EXPRESS WARRANTIES MADE IN THIS LIMITED WARRANTY MAY NOT BE ALTERED, ENLARGED, OR CHANGED BY ANY DISTRIBUTOR, DEALER, OR OTHER PERSON, WHATSOEVER.

LEGAL REMEDIES

The owner **must** notify Taylor in writing, by certified or registered letter to the following address, of any defect or complaint with the Product, stating the defect or complaint and a specific request for repair, replacement, or other correction of the Product under warranty, mailed at least thirty (30) days before pursuing any legal rights or remedies.

Taylor Company
a division of Carrier Commercial Refrigeration, Inc.
750 N. Blackhawk Blvd.
Rockton, IL 61072, U.S.A.

Section 11

Limited Warranty on Parts

TAYLOR COMPANY LIMITED WARRANTY ON TAYLOR GENUINE PARTS

Taylor Company, a division of Carrier Commercial Refrigeration, Inc. ("Taylor") is pleased to provide this limited warranty on new Taylor genuine replacement components and parts available from Taylor to the market generally (the "Parts") to the original purchaser only.

LIMITED WARRANTY

Taylor warrants the Parts against failure due to defect in materials or workmanship under normal use and service as follows. All warranty periods begin on the date of original installation of the Part in the Taylor unit. If a Part fails due to defect during the applicable warranty period, Taylor, through an authorized Taylor distributor or service agency, will provide a new or re-manufactured Part, at Taylor's option, to replace the failed defective Part at no charge for the Part. Except as otherwise stated herein, these are Taylor's exclusive obligations under this limited warranty for a Part failure. This limited warranty is subject to all provisions, conditions, limitations and exclusions listed below and on the reverse (if any) of this document.

Part's Warranty Class Code or Part	Limited Warranty Period
Class 103 Parts ¹	Three (3) months
Class 212 Parts ²	Twelve (12) months
Class 512 Parts	Twelve (12) months
Class 000 Parts	No warranty
Taylor Part #072454 (Motor-24VDC *C832/C842*)	Four (4) years

LIMITED WARRANTY CONDITIONS

1. If the date of original installation of the Part cannot be otherwise verified, proof of purchase may be required at time of service.
2. This limited warranty is valid only if the Part is installed and all required service work in connection with the Part is performed by an authorized Taylor distributor or service agency.
3. The limited warranty applies only to Parts remaining in use by their original owner at their original installation location in the unit of original installation.
4. Installation, use, care, and maintenance must be normal and in accordance with all instructions contained in the Taylor Operator's Manual.
5. Defective Parts must be returned to the authorized Taylor distributor or service agency for credit.
6. This warranty is not intended to shorten the length of any warranty coverage provided pursuant to a separate Taylor Limited Warranty on freezer or grill equipment.
7. The use of any refrigerant other than that specified for the unit in which the Part is installed will void this limited warranty.

^{1, 2} Except that Taylor Part #032129SER2 (Compressor-Air-230V SERV) and Taylor Part #075506SER1 (Compressor-Air-115V 60HZ) shall have a limited warranty period of twelve (12) months when used in Taylor freezer equipment and a limited warranty period of two (2) years when used in Taylor grill equipment.

LIMITED WARRANTY EXCEPTIONS

This limited warranty does **not** cover:

1. Labor or other costs incurred for diagnosing, repairing, removing, installing, shipping, servicing or handling of defective Parts, replacement Parts, or new Parts.
2. Normal maintenance, cleaning and lubrication as outlined in the Taylor Operator's Manual, including cleaning of condensers or carbon and grease buildup.
3. Required service, whether cleaning or general repairs, to return the cooking surface assemblies, including the upper platen and lower plate, to an operational condition to achieve proper cooking or allow proper assembly of release sheets and clips as a result of grease build-up on the cooking surfaces, including but not limited to the platen and plate, sides of the shroud or top of the shroud.
4. Replacement of cooking surfaces, including the upper platen and lower plate, due to pitting or corrosion (or in the case of the upper platen, due to loss of plating) as a result of damage due to the impact of spatulas or other small wares used during the cooking process or as a result of the use of cleaners, cleaning materials or cleaning processes not approved for use by Taylor.
5. Replacement of wear items designated as Class "000" Parts in the Taylor Operator's Manual, as well as any release sheets and clips for the Product's upper platen assembly.
6. External hoses, electrical power supplies, and machine grounding.
7. Parts not supplied or designated by Taylor, or damages resulting from their use.
8. Return trips or waiting time required because a service technician is prevented from beginning warranty service work promptly upon arrival.
9. Failure, damage or repairs due to faulty installation, misapplication, abuse, no or improper servicing, unauthorized alteration or improper operation or use as indicated in the Taylor Operator's Manual, including but not limited to the failure to use proper assembly and cleaning techniques, tools, or approved cleaning supplies.
10. Failure, damage or repairs due to theft, vandalism, wind, rain, flood, high water, water, lightning, earthquake or any other natural disaster, fire, corrosive environments, insect or rodent infestation, or other casualty, accident or condition beyond the reasonable control of Taylor; operation above or below the gas, electrical or water supply specification of the unit in which a part is installed; or Parts or the units in which they are installed repaired or altered in any way so as, in the judgment of Taylor, to adversely affect performance, or normal wear or deterioration.
11. Any Part purchased over the Internet.
12. Failure to start due to voltage conditions, blown fuses, open circuit breakers, or damages due to the inadequacy or interruption of electrical service.
13. Electricity, gas or other fuel costs, or increases in electricity or fuel costs from any reason whatsoever.
14. Damages resulting from the use of any refrigerant other than that specified for the unit in which the Part is installed will void this limited warranty.
15. Any cost to replace, refill or dispose of refrigerant, including the cost of refrigerant.
16. **ANY SPECIAL, INDIRECT OR CONSEQUENTIAL PROPERTY OR COMMERCIAL DAMAGE OF ANY NATURE WHATSOEVER.** Some jurisdictions do not allow the exclusion of incidental or consequential damages, so this limitation may not apply to you.

This limited warranty gives you specific legal rights, and you may also have other rights which vary from jurisdiction to jurisdiction.

LIMITATION OF WARRANTY

THIS LIMITED WARRANTY IS EXCLUSIVE AND IS IN LIEU OF ALL OTHER WARRANTIES, CONDITIONS AND/OR REMEDIES UNDER THE LAW, INCLUDING ANY IMPLIED WARRANTIES OR CONDITIONS OF MERCHANTABILITY OR FITNESS FOR A PARTICULAR PURPOSE. THE ORIGINAL OWNER'S SOLE REMEDY WITH RESPECT TO ANY PRODUCTS SHALL BE REPAIR OR REPLACEMENT OF DEFECTIVE PARTS UNDER THE TERMS OF THIS LIMITED WARRANTY. ALL RIGHTS TO CONSEQUENTIAL OR INCIDENTAL DAMAGES (INCLUDING CLAIMS FOR LOST SALES, LOST PROFITS, PRODUCT LOSS, PROPERTY DAMAGES OR SERVICE EXPENSES) ARE EXPRESSLY EXCLUDED. THE EXPRESS WARRANTIES MADE IN THIS LIMITED WARRANTY MAY NOT BE ALTERED, ENLARGED, OR CHANGED BY ANY DISTRIBUTOR, DEALER, OR OTHER PERSON, WHATSOEVER.

LEGAL REMEDIES

The owner **must** notify Taylor in writing, by certified or registered letter to the following address, of any defect or complaint with the Part, stating the defect or complaint and a specific request for repair, replacement, or other correction of the Part under warranty, mailed at least thirty (30) days before pursuing any legal rights or remedies.

Taylor Company
a division of Carrier Commercial Refrigeration, Inc.
750 N. Blackhawk Blvd.
Rockton, IL 61072, U.S.A.